

RULAND

Carefully Made Shaft Collars and Couplings



SHAFT COLLARS & RIGID COUPLINGS

Shaft Collars from **RULAND**



Ruland shaft collars are offered in multiple styles to fit shafts ranging from 1/8" to 6" in the inch series and 3mm to 80mm in the metric series, in a variety of materials and finishes. Collars are stamped with the Ruland name and the bore size for easy identification.

Extra steps are taken in the manufacture of Ruland shaft collars to provide important performance benefits. For example, Ruland collars are single point faced (indicated by the circular groove on the face) during the boring operation to insure perpendicularity of the face to the bore. Perpendicularity is important for alignment when collars are used as a bearing face, a mechanical stop, or for mounting other components.

One-piece clamp style collars wrap around the shaft for even distribution of clamping forces. This results in a tight fit and greater holding power, without the shaft damage caused by set screws. Ruland uses carefully selected materials and proprietary processes to ensure that the clamping gap remains open for simpler and more precise adjustment, installation and fit.

Two-piece clamp style collars offer the same benefits of the one-piece clamp collars with additional versatility and convenience. They are easily disassembled, reducing labor and downtime when adjustment, removal or replacement is necessary. Ruland keeps both halves of its two-piece collars together throughout the manufacturing process to assure a perfect match for proper fit, holding power and alignment.

Clamp style collars with threaded bores are also available. Threaded collars provide axial holding power superior to smooth bore collars, while offering easier installation and adjustment than solid ring locking devices. A diverse list of thread sizes and pitches, including metric and locknut threads, are offered.

Set screw collars are most effective when used on a shaft made of a material that is softer than the set screw. Ruland set screw collars are furnished exclusively with forged socket set screws for greater torque capacity and improved holding power. Forging of the stainless steel set screws has the additional benefit of work hardening, which results in stainless steel with elevated hardness and performance.

In This Catalog

ONE-PIECE CLAMP STYLE COLLAR (INCH)	4
TWO-PIECE CLAMP STYLE COLLAR (INCH)	5
TWO-PIECE KEYED SHAFT COLLAR (INCH)	6
TWO-PIECE HEAVY SHAFT COLLAR (INCH)	6
SET SCREW COLLAR (INCH & METRIC)	7
ONE-PIECE CLAMP STYLE THREADED COLLAR	8
ONE-PIECE BEARING LOCKNUTS	8
ONE-PIECE CLAMP STYLE COLLAR (METRIC)	9
TWO-PIECE CLAMP STYLE COLLAR (METRIC)	10
ONE-PIECE CLAMP SHAFT COLLAR (INTERNATIONAL SERIES)	11
TWO-PIECE CLAMP SHAFT COLLAR (INTERNATIONAL SERIES)	11
QUICK CLAMPING SHAFT COLLAR (INCH & METRIC)	12
DOUBLE-WIDE ONE- AND TWO-PIECE CLAMP STYLE COLLAR (INCH)	13
DOUBLE-WIDE ONE- AND TWO-PIECE CLAMP STYLE COLLAR (METRIC)	14
ONE- AND TWO-PIECE RIGID COUPLINGS WITHOUT KEYWAY (INCH)	15
ONE- AND TWO-PIECE RIGID COUPLINGS WITH KEYWAY (INCH)	16
ONE- AND TWO-PIECE RIGID COUPLINGS WITHOUT OR WITH KEYWAY (METRIC)	17
SET SCREW RIGID COUPLINGS WITHOUT OR WITH KEYWAY (INCH & METRIC)	18

Rigid Couplings from **RULAND**



Ruland's rigid couplings are available in one- and two-piece clamp designs, and set screw style, with and without keyways in a variety of materials. A large number of standard sizes are available to fit shafts from 1/8" to 2" in the inch series and 3mm to 50mm in the metric series. Rigid couplings are stamped with the Ruland name and the bore sizes for easy identification.

Clamp style rigid couplings wrap around the shaft, providing high torsional holding power without the shaft damage and fretting that occurs when set screw style couplings are used. Two-piece clamp styles also allow for disassembly and maintenance without removal of other machine components and feature opposing hardware for a balanced design.

We take extra steps in the manufacture of rigid couplings to provide important performance benefits. For example, the bores of Ruland straight-bore couplings are precision honed. Honing ensures the bores are concentric and also corrects any residual distortions caused by stresses introduced during the manufacturing process. This results in a round, precisely sized bore yielding easier installation and greater torque transmission capability.



Clamp style rigid couplings are supplied with Ruland's Nypatch[®] socket head cap screws. Nypatch[®] involves a process of depositing a 360° ring of nylon on several threads of the screws. This coating reduces screw vibration, which can cause the screws to loosen and torque transmission ability to diminish during the course of normal use.

WARRANTY / DISCLAIMER OF UNSTATED WARRANTIES / LIMITATION OF LIABILITY

Warranty. Ruland warrants that the products sold hereunder meet Ruland's size and materials specifications as set forth in this catalog. Products not meeting Ruland's size and material specifications will, at Ruland's option, be replaced or the purchase price refunded.

Disclaimer of unstated warranties. THE WARRANTY PRINTED ABOVE IS THE ONLY WARRANTY APPLICABLE TO THESE PRODUCTS. ALL OTHER WARRANTIES, EXPRESS OR IMPLIED, INCLUDING BUT NOT LIMITED TO THE IMPLIED WARRANTIES OF MERCHANTABILITY AND FITNESS FOR A PARTICULAR PURPOSE ARE DISCLAIMED. It is the responsibility of the user to determine the suitability of Ruland products for a specific application. No person, including employees of Ruland or agents in the company's channels of distribution is authorized to represent on Ruland's behalf, the suitability of Ruland products for a specific purpose.

Limitation of Liability. IT IS UNDERSTOOD AND AGREED THAT SELLER'S LIABILITY SHALL NOT EXCEED THE AMOUNT OF THE PURCHASE PRICE. SELLER SHALL NOT BE LIABLE FOR SPECIAL, INDIRECT OR CONSEQUENTIAL DAMAGES. THE PRICE STATED FOR THE PRODUCT IS A CONSIDERATION IN LIMITING RULAND'S LIABILITY.

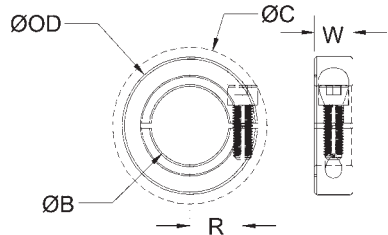

PART NUMBER						SPECIFICATIONS					
BLACK OXIDE STEEL	ZINC PLATED STEEL	ALUMINUM	STAINLESS STEEL	316 STAINLESS STEEL	PLASTIC	BORE B (in)	OUTER DIAM. OD (in)	SCREW LOCATION R (in)	CLEARANCE DIAM. C (in) MAX	WIDTH W (in)	FORGED CLAMP SCREW
CL-2-F	CL-2-FZ	CL-2-A	CL-2-SS	CL-2-ST	CL-2-P	0.1250	5/8	0.210	0.773	0.281	#4-40
CL-3-F	CL-3-FZ	CL-3-A	CL-3-SS	CL-3-ST	CL-3-P	0.1875	5/8	0.210	0.773	0.281	#4-40
CL-4-F	CL-4-FZ	CL-4-A	CL-4-SS	CL-4-ST	CL-4-P	0.2500	5/8	0.210	0.773	0.281	#4-40
CL-5-F	CL-5-FZ	CL-5-A	CL-5-SS	CL-5-ST	CL-5-P	0.3125	11/16	0.250	0.838	0.281	#4-40
CL-6-F	CL-6-FZ	CL-6-A	CL-6-SS	CL-6-ST	CL-6-P	0.3750	7/8	0.313	1.027	0.343	#6-32
CL-7-F	CL-7-FZ	CL-7-A	CL-7-SS	CL-7-ST	CL-7-P	0.4375	15/16	0.344	1.080	0.343	#6-32
CL-8-F	CL-8-FZ	CL-8-A	CL-8-SS	CL-8-ST	CL-8-P	0.5000	1-1/8	0.406	1.281	0.406	#8-32
CL-9-F	CL-9-FZ	CL-9-A	CL-9-SS	CL-9-ST	CL-9-P	0.5625	1-1/4	0.448	1.448	0.437	#10-32
CL-10-F	CL-10-FZ	CL-10-A	CL-10-SS	CL-10-ST	CL-10-P	0.6250	1-5/16	0.479	1.500	0.437	#10-32
CL-11-F	CL-11-FZ	CL-11-A	CL-11-SS	CL-11-ST	CL-11-P	0.6875	1-3/8	0.516	1.564	0.437	#10-32
CL-12-F	CL-12-FZ	CL-12-A	CL-12-SS	CL-12-ST	CL-12-P	0.7500	1-1/2	0.545	1.808	0.500	1/4-28
CL-13-F	CL-13-FZ	CL-13-A	CL-13-SS	CL-13-ST	CL-13-P	0.8125	1-5/8	0.610	1.916	0.500	1/4-28
CL-14-F	CL-14-FZ	CL-14-A	CL-14-SS	CL-14-ST	CL-14-P	0.8750	1-5/8	0.610	1.916	0.500	1/4-28
CL-15-F	CL-15-FZ	CL-15-A	CL-15-SS	CL-15-ST	CL-15-P	0.9375	1-3/4	0.678	2.032	0.500	1/4-28
CL-16-F	CL-16-FZ	CL-16-A	CL-16-SS	CL-16-ST	CL-16-P	1.0000	1-3/4	0.678	2.032	0.500	1/4-28
CL-17-F	CL-17-FZ	CL-17-A	CL-17-SS	CL-17-ST	CL-17-P	1.0625	1-7/8	0.740	2.140	0.500	1/4-28
CL-18-F	CL-18-FZ	CL-18-A	CL-18-SS	CL-18-ST	CL-18-P	1.1250	1-7/8	0.740	2.140	0.500	1/4-28
CL-19-F	CL-19-FZ	CL-19-A	CL-19-SS	CL-19-ST	CL-19-P	1.1875	2-1/16	0.828	2.295	0.500	1/4-28
CL-20-F	CL-20-FZ	CL-20-A	CL-20-SS	CL-20-ST	CL-20-P	1.2500	2-1/16	0.828	2.295	0.500	1/4-28
CL-21-F	CL-21-FZ	CL-21-A	CL-21-SS	CL-21-ST	CL-21-P	1.3125	2-1/8	0.859	2.351	0.563	1/4-28
CL-22-F	CL-22-FZ	CL-22-A	CL-22-SS	CL-22-ST	CL-22-P	1.3750	2-1/4	0.922	2.465	0.563	1/4-28
CL-23-F	CL-23-FZ	CL-23-A	CL-23-SS	CL-23-ST	CL-23-P	1.4375	2-1/4	0.922	2.465	0.563	1/4-28
CL-24-F	CL-24-FZ	CL-24-A	CL-24-SS	CL-24-ST	CL-24-P	1.5000	2-3/8	0.984	2.578	0.563	1/4-28
CL-25-F	CL-25-FZ	CL-25-A	CL-25-SS	CL-25-ST		1.5625	2-3/8	0.984	2.578	0.563	1/4-28
CL-26-F	CL-26-FZ	CL-26-A	CL-26-SS	CL-26-ST		1.6250	2-5/8	1.063	2.935	0.688	5/16-24
CL-27-F	CL-27-FZ	CL-27-A	CL-27-SS	CL-27-ST		1.6875	2-3/4	1.125	3.046	0.688	5/16-24
CL-28-F	CL-28-FZ	CL-28-A	CL-28-SS	CL-28-ST		1.7500	2-3/4	1.125	3.046	0.688	5/16-24
CL-29-F	CL-29-FZ	CL-29-A	CL-29-SS	CL-29-ST		1.8125	2-7/8	1.188	3.160	0.688	5/16-24
CL-30-F	CL-30-FZ	CL-30-A	CL-30-SS	CL-30-ST		1.8750	2-7/8	1.188	3.160	0.688	5/16-24
CL-31-F	CL-31-FZ	CL-31-A	CL-31-SS	CL-31-ST		1.9375	3	1.250	3.273	0.688	5/16-24
CL-32-F	CL-32-FZ	CL-32-A	CL-32-SS	CL-32-ST		2.0000	3	1.250	3.273	0.688	5/16-24
CL-33-F	CL-33-FZ	CL-33-A	CL-33-SS	CL-33-ST		2.0625	3-1/8	1.297	3.360	0.750	5/16-24
CL-34-F	CL-34-FZ	CL-34-A	CL-34-SS	CL-34-ST		2.1250	3-1/4	1.375	3.504	0.750	5/16-24
CL-35-F	CL-35-FZ	CL-35-A	CL-35-SS	CL-35-ST		2.1875	3-1/4	1.375	3.504	0.750	5/16-24
CL-36-F	CL-36-FZ	CL-36-A	CL-36-SS	CL-36-ST		2.2500	3-1/4	1.375	3.504	0.750	5/16-24
CL-37-F	CL-37-FZ	CL-37-A	CL-37-SS	CL-37-ST		2.3125	3-3/8	1.422	3.591	0.750	5/16-24
CL-38-F	CL-38-FZ	CL-38-A	CL-38-SS	CL-38-ST		2.3750	3-1/2	1.484	3.707	0.750	5/16-24
CL-39-F	CL-39-FZ	CL-39-A	CL-39-SS	CL-39-ST		2.4375	3-1/2	1.484	3.707	0.750	5/16-24
CL-40-F	CL-40-FZ	CL-40-A	CL-40-SS	CL-40-ST		2.5000	3-3/4	1.563	4.034	0.875	3/8-24
CL-41-F	CL-41-FZ	CL-41-A	CL-41-SS	CL-41-ST		2.5625	3-7/8	1.625	4.148	0.875	3/8-24
CL-42-F	CL-42-FZ	CL-42-A	CL-42-SS	CL-42-ST		2.6250	3-7/8	1.625	4.148	0.875	3/8-24
CL-43-F	CL-43-FZ	CL-43-A	CL-43-SS	CL-43-ST		2.6875	4	1.688	4.265	0.875	3/8-24
CL-44-F	CL-44-FZ	CL-44-A	CL-44-SS	CL-44-ST		2.7500	4	1.688	4.265	0.875	3/8-24
CL-45-F	CL-45-FZ	CL-45-A	CL-45-SS	CL-45-ST		2.8125	4-1/4	1.813	4.499	0.875	3/8-24
CL-46-F	CL-46-FZ	CL-46-A	CL-46-SS	CL-46-ST		2.8750	4-1/4	1.813	4.499	0.875	3/8-24
CL-47-F	CL-47-FZ	CL-47-A	CL-47-SS	CL-47-ST		2.9375	4-1/4	1.813	4.499	0.875	3/8-24
CL-48-F	CL-48-FZ	CL-48-A	CL-48-SS	CL-48-ST		3.0000	4-1/4	1.813	4.499	0.875	3/8-24

Note: Sizes CL-25 through CL-48 do not have backslot.

- Does not mar the shaft.
- Single point faced.
- Balanced versions available.
- Width tolerance: +.003" - .010"
- Bore tolerance: +.002" +.0005"

For engineering and warranty/disclaimer information, see pp. 3 and 19 or www.ruland.com

TWO-PIECE CLAMP STYLE COLLAR

INCH DIMENSION SERIES

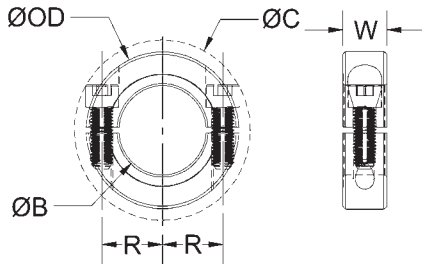
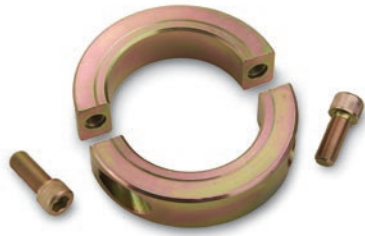

- Does not mar the shaft.
- Single point faced.
- Available with keyways.
- Opposing screws available.
- Width tolerance: +.003"
-.010"
- Bore tolerance: +.002"
+.0005"

PART NUMBER						SPECIFICATIONS					
BLACK OXIDE STEEL	ZINC PLATED STEEL	ALUMINUM	STAINLESS STEEL	316 STAINLESS STEEL	PLASTIC	BORE B (in)	OUTER DIAM. OD (in)	SCREW LOCATION R (in)	CLEARANCE DIAM. C (in) MAX	WIDTH W (in)	FORGED CLAMP SCREW
SP-2-F	SP-2-FZ	SP-2-A	SP-2-SS	SP-2-ST	SP-2-P	0.1250	5/8	0.210	0.773	0.281	#4-40
SP-3-F	SP-3-FZ	SP-3-A	SP-3-SS	SP-3-ST	SP-3-P	0.1875	5/8	0.210	0.773	0.281	#4-40
SP-4-F	SP-4-FZ	SP-4-A	SP-4-SS	SP-4-ST	SP-4-P	0.2500	5/8	0.210	0.773	0.281	#4-40
SP-5-F	SP-5-FZ	SP-5-A	SP-5-SS	SP-5-ST	SP-5-P	0.3125	11/16	0.250	0.838	0.281	#4-40
SP-6-F	SP-6-FZ	SP-6-A	SP-6-SS	SP-6-ST	SP-6-P	0.3750	7/8	0.313	1.027	0.343	#6-32
SP-7-F	SP-7-FZ	SP-7-A	SP-7-SS	SP-7-ST	SP-7-P	0.4375	15/16	0.344	1.080	0.343	#6-32
SP-8-F	SP-8-FZ	SP-8-A	SP-8-SS	SP-8-ST	SP-8-P	0.5000	1-1/8	0.406	1.281	0.406	#8-32
SP-9-F	SP-9-FZ	SP-9-A	SP-9-SS	SP-9-ST	SP-9-P	0.5625	1-1/4	0.448	1.448	0.437	#10-32
SP-10-F	SP-10-FZ	SP-10-A	SP-10-SS	SP-10-ST	SP-10-P	0.6250	1-5/16	0.479	1.500	0.437	#10-32
SP-11-F	SP-11-FZ	SP-11-A	SP-11-SS	SP-11-ST	SP-11-P	0.6875	1-3/8	0.516	1.564	0.437	#10-32
SP-12-F	SP-12-FZ	SP-12-A	SP-12-SS	SP-12-ST	SP-12-P	0.7500	1-1/2	0.545	1.808	0.500	1/4-28
SP-13-F	SP-13-FZ	SP-13-A	SP-13-SS	SP-13-ST	SP-13-P	0.8125	1-5/8	0.610	1.916	0.500	1/4-28
SP-14-F	SP-14-FZ	SP-14-A	SP-14-SS	SP-14-ST	SP-14-P	0.8750	1-5/8	0.610	1.916	0.500	1/4-28
SP-15-F	SP-15-FZ	SP-15-A	SP-15-SS	SP-15-ST	SP-15-P	0.9375	1-3/4	0.678	2.032	0.500	1/4-28
SP-16-F	SP-16-FZ	SP-16-A	SP-16-SS	SP-16-ST	SP-16-P	1.0000	1-3/4	0.678	2.032	0.500	1/4-28
SP-17-F	SP-17-FZ	SP-17-A	SP-17-SS	SP-17-ST	SP-17-P	1.0625	1-7/8	0.740	2.140	0.500	1/4-28
SP-18-F	SP-18-FZ	SP-18-A	SP-18-SS	SP-18-ST	SP-18-P	1.1250	1-7/8	0.740	2.140	0.500	1/4-28
SP-19-F	SP-19-FZ	SP-19-A	SP-19-SS	SP-19-ST	SP-19-P	1.1875	2-1/16	0.828	2.295	0.500	1/4-28
SP-20-F	SP-20-FZ	SP-20-A	SP-20-SS	SP-20-ST	SP-20-P	1.2500	2-1/16	0.828	2.295	0.500	1/4-28
SP-21-F	SP-21-FZ	SP-21-A	SP-21-SS	SP-21-ST	SP-21-P	1.3125	2-1/8	0.859	2.351	0.563	1/4-28
SP-22-F	SP-22-FZ	SP-22-A	SP-22-SS	SP-22-ST	SP-22-P	1.3750	2-1/4	0.922	2.465	0.563	1/4-28
SP-23-F	SP-23-FZ	SP-23-A	SP-23-SS	SP-23-ST	SP-23-P	1.4375	2-1/4	0.922	2.465	0.563	1/4-28
SP-24-F	SP-24-FZ	SP-24-A	SP-24-SS	SP-24-ST	SP-24-P	1.5000	2-3/8	0.984	2.578	0.563	1/4-28
SP-25-F	SP-25-FZ	SP-25-A	SP-25-SS	SP-25-ST		1.5625	2-3/8	0.984	2.578	0.563	1/4-28
SP-26-F	SP-26-FZ	SP-26-A	SP-26-SS	SP-26-ST		1.6250	2-5/8	1.063	2.935	0.688	5/16-24
SP-27-F	SP-27-FZ	SP-27-A	SP-27-SS	SP-27-ST		1.6875	2-3/4	1.125	3.046	0.688	5/16-24
SP-28-F	SP-28-FZ	SP-28-A	SP-28-SS	SP-28-ST		1.7500	2-3/4	1.125	3.046	0.688	5/16-24
SP-29-F	SP-29-FZ	SP-29-A	SP-29-SS	SP-29-ST		1.8125	2-7/8	1.188	3.160	0.688	5/16-24
SP-30-F	SP-30-FZ	SP-30-A	SP-30-SS	SP-30-ST		1.8750	2-7/8	1.188	3.160	0.688	5/16-24
SP-31-F	SP-31-FZ	SP-31-A	SP-31-SS	SP-31-ST		1.9375	3	1.250	3.273	0.688	5/16-24
SP-32-F	SP-32-FZ	SP-32-A	SP-32-SS	SP-32-ST		2.0000	3	1.250	3.273	0.688	5/16-24
SP-33-F	SP-33-FZ	SP-33-A	SP-33-SS	SP-33-ST		2.0625	3-1/8	1.297	3.360	0.750	5/16-24
SP-34-F	SP-34-FZ	SP-34-A	SP-34-SS	SP-34-ST		2.1250	3-1/4	1.375	3.504	0.750	5/16-24
SP-35-F	SP-35-FZ	SP-35-A	SP-35-SS	SP-35-ST		2.1875	3-1/4	1.375	3.504	0.750	5/16-24
SP-36-F	SP-36-FZ	SP-36-A	SP-36-SS	SP-36-ST		2.2500	3-1/4	1.375	3.504	0.750	5/16-24
SP-37-F	SP-37-FZ	SP-37-A	SP-37-SS	SP-37-ST		2.3125	3-3/8	1.422	3.591	0.750	5/16-24
SP-38-F	SP-38-FZ	SP-38-A	SP-38-SS	SP-38-ST		2.3750	3-1/2	1.484	3.707	0.750	5/16-24
SP-39-F	SP-39-FZ	SP-39-A	SP-39-SS	SP-39-ST		2.4375	3-1/2	1.484	3.707	0.750	5/16-24
SP-40-F	SP-40-FZ	SP-40-A	SP-40-SS	SP-40-ST		2.5000	3-3/4	1.563	4.034	0.875	3/8-24
SP-41-F	SP-41-FZ	SP-41-A	SP-41-SS	SP-41-ST		2.5625	3-7/8	1.625	4.148	0.875	3/8-24
SP-42-F	SP-42-FZ	SP-42-A	SP-42-SS	SP-42-ST		2.6250	3-7/8	1.625	4.148	0.875	3/8-24
SP-43-F	SP-43-FZ	SP-43-A	SP-43-SS	SP-43-ST		2.6875	4	1.688	4.265	0.875	3/8-24
SP-44-F	SP-44-FZ	SP-44-A	SP-44-SS	SP-44-ST		2.7500	4	1.688	4.265	0.875	3/8-24
SP-45-F	SP-45-FZ	SP-45-A	SP-45-SS	SP-45-ST		2.8125	4-1/4	1.813	4.499	0.875	3/8-24
SP-46-F	SP-46-FZ	SP-46-A	SP-46-SS	SP-46-ST		2.8750	4-1/4	1.813	4.499	0.875	3/8-24
SP-47-F	SP-47-FZ	SP-47-A	SP-47-SS	SP-47-ST		2.9375	4-1/4	1.813	4.499	0.875	3/8-24
SP-48-F	SP-48-FZ	SP-48-A	SP-48-SS	SP-48-ST		3.0000	4-1/4	1.813	4.499	0.875	3/8-24
SP-49-F						3.0625	4-1/2	1.938	4.742	0.875	3/8-24
SP-50-F						3.1250	4-1/2	1.938	4.742	0.875	3/8-24
SP-51-F						3.1875	4-1/2	1.938	4.742	0.875	3/8-24
SP-52-F						3.2500	4-1/2	1.938	4.742	0.875	3/8-24
SP-53-F						3.3125	4-3/4	2.063	4.978	0.875	3/8-24
SP-54-F						3.3750	4-3/4	2.063	4.978	0.875	3/8-24
SP-55-F						3.4375	4-3/4	2.063	4.978	0.875	3/8-24
SP-56-F						3.5000	4-3/4	2.063	4.978	0.875	3/8-24
SP-57-F						3.5625	5	2.188	5.216	0.875	3/8-24
SP-58-F						3.6250	5	2.188	5.216	0.875	3/8-24
SP-59-F						3.6875	5	2.188	5.216	0.875	3/8-24
SP-60-F						3.7500	5	2.188	5.216	0.875	3/8-24
SP-61-F						3.8125	5-1/4	2.313	5.456	0.875	3/8-24
SP-62-F						3.8750	5-1/4	2.313	5.456	0.875	3/8-24
SP-63-F						3.9375	5-1/4	2.313	5.456	0.875	3/8-24
SP-64-F						4.0000	5-1/4	2.313	5.456	0.875	3/8-24

For engineering and warranty/disclaimer information, see pp. 3 and 19 or www.ruland.com

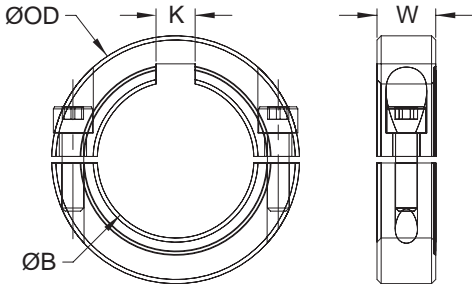

- Does not mar the shaft
- Single point faced
- Opposing screws available
- Width tolerance: +.003" - .010"
- Bore tolerance:
SPK +.002"/+.0005"
SPH +.004"/-.000"
- Additional sizes available on request

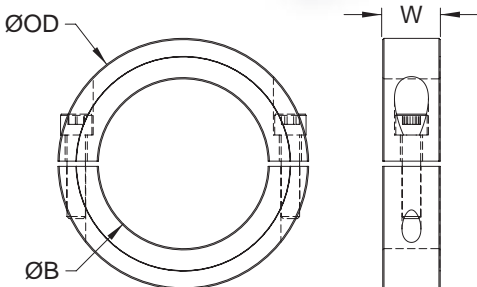

PART NUMBER			SPECIFICATIONS				
STEEL	ALUMINUM	STAINLESS STEEL	BORE B (in)	KEYWAY K (in)	OUTER DIAM. OD (in)	WIDTH W (in)	FORGED CLAMP SCREW
SPK-6-F	SPK-6-A	SPK-6-SS	0.3750	3/32	7/8	0.343	#6-32X3/8
SPK-8-F	SPK-8-A	SPK-8-SS	0.5000	1/8	1 1/8	0.406	#8-32X1/2
SPK-10-F	SPK-10-A	SPK-10-SS	0.6250	3/16	1 5/16	0.437	#10-32X1/2
SPK-12-F	SPK-12-A	SPK-12-SS	0.7500	3/16	1 1/2	0.500	1/4-28X5/8
SPK-16-F	SPK-16-A	SPK-16-SS	1.0000	1/4	1 3/4	0.500	1/4-28X11/16
SPK-20-F	SPK-20-A	SPK-20-SS	1.2500	1/4	2 1/16	0.500	1/4-28X11/16
SPK-24-F	SPK-24-A	SPK-24-SS	1.5000	3/8	2 3/8	0.563	1/4-28X3/4
SPK-28-F	SPK-28-A	SPK-28-SS	1.7500	3/8	2 3/4	0.688	5/16-24X7/8
SPK-32-F	SPK-32-A	SPK-32-SS	2.0000	1/2	3	0.688	5/16-24X7/8
SPK-35-F	SPK-35-A	SPK-35-SS	2.1875	1/2	3 1/4	0.750	5/16-24X7/8
SPK-39-F	SPK-39-A	SPK-39-SS	2.4375	5/8	3 1/2	0.750	5/16-24X7/8
STEEL			BORE B (in)		OUTER DIAM. OD (in)	WIDTH W (in)	FORGED CLAMP SCREW
SPH-49-F			3.063		5	1.375	1/2-20X1 3/4
SPH-50-F			3.125		5	1.375	1/2-20X1 3/4
SPH-51-F			3.188		5	1.375	1/2-20X1 3/4
SPH-52-F			3.250		5	1.375	1/2-20X1 3/4
SPH-53-F			3.313		5 1/4	1.375	1/2-20X1 3/4
SPH-54-F			3.375		5 1/4	1.375	1/2-20X1 3/4
SPH-55-F			3.438		5 1/4	1.375	1/2-20X1 3/4
SPH-56-F			3.500		5 1/4	1.375	1/2-20X1 3/4
SPH-57-F			3.563		5 1/2	1.375	1/2-20X1 3/4
SPH-58-F			3.625		5 1/2	1.375	1/2-20X1 3/4
SPH-59-F			3.688		5 1/2	1.375	1/2-20X1 3/4
SPH-60-F			3.750		5 1/2	1.375	1/2-20X1 3/4
SPH-61-F			3.813		5 3/4	1.375	1/2-20X1 3/4
SPH-62-F			3.875		5 3/4	1.375	1/2-20X1 3/4
SPH-63-F			3.938		5 3/4	1.375	1/2-20X1 3/4
SPH-64-F			4.000		5 3/4	1.375	1/2-20X1 3/4
SPH-65-F			4.063		6	1.375	1/2-20X2
SPH-66-F			4.125		6	1.375	1/2-20X2
SPH-67-F			4.188		6	1.375	1/2-20X2
SPH-68-F			4.250		6	1.375	1/2-20X2
SPH-69-F			4.313		6 1/4	1.375	1/2-20X2
SPH-70-F			4.375		6 1/4	1.375	1/2-20X2
SPH-71-F			4.438		6 1/4	1.375	1/2-20X2
SPH-72-F			4.500		6 1/4	1.375	1/2-20X2
SPH-73-F			4.563		6 1/2	1.375	1/2-20X2
SPH-74-F			4.625		6 1/2	1.375	1/2-20X2
SPH-75-F			4.688		6 1/2	1.375	1/2-20X2
SPH-76-F			4.750		6 1/2	1.375	1/2-20X2
SPH-77-F			4.813		6 3/4	1.375	1/2-20X2
SPH-78-F			4.875		6 3/4	1.375	1/2-20X2
SPH-79-F			4.938		6 3/4	1.375	1/2-20X2
SPH-80-F			5.000		6 3/4	1.375	1/2-20X2
SPH-81-F			5.063		7	1.375	1/2-20X2
SPH-82-F			5.125		7	1.375	1/2-20X2
SPH-83-F			5.188		7	1.375	1/2-20X2
SPH-84-F			5.250		7	1.375	1/2-20X2
SPH-85-F			5.313		7 1/4	1.375	1/2-20X2
SPH-86-F			5.375		7 1/4	1.375	1/2-20X2
SPH-87-F			5.438		7 1/4	1.375	1/2-20X2
SPH-88-F			5.500		7 1/4	1.375	1/2-20X2
SPH-89-F			5.563		7 1/2	1.375	1/2-20X2
SPH-90-F			5.625		7 1/2	1.375	1/2-20X2
SPH-91-F			5.688		7 1/2	1.375	1/2-20X2
SPH-92-F			5.750		7 1/2	1.375	1/2-20X2
SPH-93-F			5.813		7 3/4	1.375	1/2-20X2
SPH-94-F			5.875		7 3/4	1.375	1/2-20X2
SPH-95-F			5.938		7 3/4	1.375	1/2-20X2
SPH-96-F			6.000		7 3/4	1.375	1/2-20X2

For engineering and warranty/disclaimer information, see pp. 3 and 19 or www.ruland.com

SET SCREW COLLAR

INCH AND METRIC DIMENSION SERIES

SC
MSC

PART NUMBER				SPECIFICATIONS			
BLACK OXIDE STEEL	ALUMINUM	STAINLESS STEEL	PLASTIC	BORE B (in)	OUTER DIAM. OD (in)	WIDTH W (in)	FORGED SET SCREW
SC-3-F	SC-3-A	SC-3-SS	SC-3-P	0.1875	7/16	0.250	#8-32x1/8
SC-4-F	SC-4-A	SC-4-SS	SC-4-P	0.2500	1/2	0.281	#8-32x1/8
SC-5-F	SC-5-A	SC-5-SS	SC-5-P	0.3125	5/8	0.344	#10-32x5/32
SC-6-F	SC-6-A	SC-6-SS	SC-6-P	0.3750	3/4	0.375	1/4-20x3/16
SC-7-F	SC-7-A	SC-7-SS	SC-7-P	0.4375	7/8	0.438	1/4-20x1/4
SC-8-F	SC-8-A	SC-8-SS	SC-8-P	0.5000	1	0.438	1/4-20x1/4
SC-9-F	SC-9-A	SC-9-SS	SC-9-P	0.5625	1	0.438	1/4-20x1/4
SC-10-F	SC-10-A	SC-10-SS	SC-10-P	0.6250	1-1/8	0.500	5/16-18x1/4
SC-11-F	SC-11-A	SC-11-SS	SC-11-P	0.6875	1-1/4	0.563	5/16-18x1/4
SC-12-F	SC-12-A	SC-12-SS	SC-12-P	0.7500	1-1/4	0.563	5/16-18x1/4
SC-13-F		SC-13-SS		0.8125	1-5/16	0.563	5/16-18x1/4
SC-14-F		SC-14-SS		0.8750	1-1/2	0.563	5/16-18x5/16
SC-15-F		SC-15-SS		0.9375	1-5/8	0.563	5/16-18x5/16
SC-16-F		SC-16-SS		1.0000	1-5/8	0.625	5/16-18x5/16
SC-17-F		SC-17-SS		1.0625	1-3/4	0.625	5/16-18x5/16
SC-18-F		SC-18-SS		1.1250	1-3/4	0.625	5/16-18x5/16
SC-19-F		SC-19-SS		1.1875	2	0.688	3/8-16x3/8
SC-20-F		SC-20-SS		1.2500	2	0.688	3/8-16x3/8
SC-21-F		SC-21-SS		1.3125	2-1/8	0.688	3/8-16x3/8
SC-22-F		SC-22-SS		1.3750	2-1/8	0.750	3/8-16x3/8
SC-23-F		SC-23-SS		1.4375	2-1/4	0.750	3/8-16x3/8
SC-24-F		SC-24-SS		1.5000	2-1/4	0.750	3/8-16x3/8
SC-26-F		SC-26-SS		1.6250	2-1/2	0.813	3/8-16x3/8
SC-28-F		SC-28-SS		1.7500	2-3/4	0.875	1/2-13x1/2
SC-31-F		SC-31-SS		1.9375	3	0.875	1/2-13x1/2
SC-32-F		SC-32-SS		2.0000	3	0.875	1/2-13x1/2
SC-33-F		SC-33-SS		2.0625	3	0.875	1/2-13x1/2
SC-34-F		SC-34-SS		2.1250	3	0.875	1/2-13x1/2
SC-36-F		SC-36-SS		2.2500	3-1/4	0.938	1/2-13x1/2
SC-38-F		SC-38-SS		2.3750	3-1/4	0.938	1/2-13x1/2
SC-39-F		SC-39-SS		2.4375	3-1/2	1.000	1/2-13x1/2
SC-40-F		SC-40-SS		2.5000	3-1/2	1.000	1/2-13x1/2
SC-44-F		SC-44-SS		2.7500	4	1.125	1/2-13x5/8
SC-47-F		SC-47-SS		2.9375	4-1/4	1.125	1/2-13x5/8
SC-48-F		SC-48-SS		3.0000	4-1/4	1.125	1/2-13x5/8
SC-55-F				3.4375	4-3/4	1.125	1/2-13x5/8
SC-56-F				3.5000	4-3/4	1.125	1/2-13x5/8
SC-63-F				3.9375	5-1/4	1.125	1/2-13x5/8
SC-64-F				4.0000	5-1/4	1.125	1/2-13x5/8
BLACK OXIDE STEEL		STAINLESS STEEL		BORE B (mm)	OUTER DIAM. OD (mm)	WIDTH W (mm)	FORGED SET SCREW
MSC-4-F		MSC-4-SS		4	8	5	M2.5x3
MSC-5-F		MSC-5-SS		5	10	6	M3x4
MSC-6-F		MSC-6-SS		6	12	8	M4x4
MSC-8-F		MSC-8-SS		8	16	8	M4x4
MSC-10-F		MSC-10-SS		10	20	10	M5x5
MSC-12-F		MSC-12-SS		12	22	12	M6x6
MSC-14-F		MSC-14-SS		14	25	12	M6x6
MSC-15-F		MSC-15-SS		15	25	12	M6x6
MSC-16-F		MSC-16-SS		16	28	12	M6x8
MSC-18-F		MSC-18-SS		18	32	14	M6x8
MSC-20-F		MSC-20-SS		20	32	14	M6x8
MSC-22-F		MSC-22-SS		22	36	14	M6x8
MSC-25-F		MSC-25-SS		25	40	16	M8x8
MSC-28-F		MSC-28-SS		28	45	16	M8x10
MSC-30-F		MSC-30-SS		30	45	16	M8x8
MSC-32-F		MSC-32-SS		32	50	16	M8x10
MSC-35-F		MSC-35-SS		35	56	16	M8x12
MSC-38-F		MSC-38-SS		38	56	16	M8x10
MSC-40-F		MSC-40-SS		40	63	18	M10x12
MSC-45-F		MSC-45-SS		45	70	18	M10x12
MSC-50-F		MSC-50-SS		50	80	18	M10x16

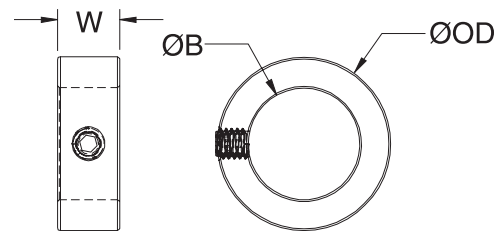

- Forged socket set screws.
- Additional sizes available.

INCH SIZES:

- Bore tolerances for SC styles:
- | BORE | TOLERANCE |
|---------------|--------------------|
| Up to 1" | +0.005" to +0.002" |
| 1-1/16" to 3" | +0.005" to +0.003" |
| 3-1/16" to 4" | +0.010" to +0.004" |

- Width tolerance: +0.003" -0.010"

METRIC SIZES:

- Bore tolerance: +0.050 mm +0.012 mm
- Width tolerance: +0.076 mm -0.254 mm

For engineering and warranty/disclaimer information, see pp. 3 and 19 or www.ruland.com

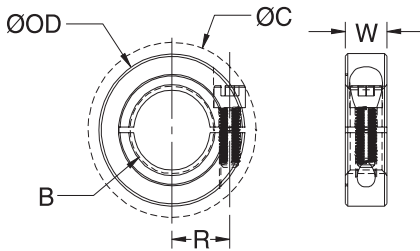

- Does not mar the shaft.
- Single point faced.
- Acme and Left-hand threads available.
- Additional sizes available.
- Width tolerance:
+.003" / -.010"
+.076 mm / -.254 mm

PART NUMBER		SPECIFICATIONS					
BLACK OXIDE STEEL	STAINLESS STEEL	BORE B	OUTER DIAM. OD (in)	SCREW LOCATION R (in)	CLEARANCE DIAM. C (in) MAX	WIDTH W (in)	FORGED CLAMP SCREW
TCL-2-32-F	TCL-2-32-SS	#8-32	5/8	0.210	0.773	0.281	#4-40
TCL-3-24-F	TCL-3-24-SS	#10-24	5/8	0.210	0.773	0.281	#4-40
TCL-3-32-F	TCL-3-32-SS	#10-32	5/8	0.210	0.773	0.281	#4-40
TCL-4-20-F	TCL-4-20-SS	1/4-20	5/8	0.210	0.773	0.281	#4-40
TCL-4-28-F	TCL-4-28-SS	1/4-28	5/8	0.210	0.773	0.281	#4-40
TCL-5-18-F	TCL-5-18-SS	5/16-18	11/16	0.250	0.838	0.281	#4-40
TCL-5-24-F	TCL-5-24-SS	5/16-24	11/16	0.250	0.838	0.281	#4-40
TCL-6-16-F	TCL-6-16-SS	3/8-16	7/8	0.313	1.027	0.343	#6-32
TCL-6-24-F	TCL-6-24-SS	3/8-24	7/8	0.313	1.027	0.343	#6-32
TCL-7-14-F	TCL-7-14-SS	7/16-14	15/16	0.344	1.080	0.343	#6-32
TCL-7-20-F	TCL-7-20-SS	7/16-20	15/16	0.344	1.080	0.343	#6-32
TCL-8-13-F	TCL-8-13-SS	1/2-13	1-1/8	0.406	1.281	0.406	#8-32
TCL-8-20-F	TCL-8-20-SS	1/2-20	1-1/8	0.406	1.281	0.406	#8-32
TCL-10-11-F	TCL-10-11-SS	5/8-11	1-5/16	0.479	1.500	0.437	#10-32
TCL-10-18-F	TCL-10-18-SS	5/8-18	1-5/16	0.479	1.500	0.437	#10-32
TCL-12-10-F	TCL-12-10-SS	3/4-10	1-1/2	0.545	1.808	0.500	1/4-28
TCL-12-16-F	TCL-12-16-SS	3/4-16	1-1/2	0.545	1.808	0.500	1/4-28
TCL-14-9-F	TCL-14-9-SS	7/8-9	1-5/8	0.610	1.916	0.500	1/4-28
TCL-14-14-F	TCL-14-14-SS	7/8-14	1-5/8	0.610	1.916	0.500	1/4-28
TCL-16-8-F	TCL-16-8-SS	1-8	1-3/4	0.678	2.032	0.500	1/4-28
TCL-16-12-F	TCL-16-12-SS	1-12	1-3/4	0.678	2.032	0.500	1/4-28
TCL-16-14-F	TCL-16-14-SS	1-14	1-3/4	0.678	2.032	0.500	1/4-28
TCL-18-12-F	TCL-18-12-SS	1-1/8-12	1-7/8	0.740	2.140	0.500	1/4-28
TCL-20-7-F	TCL-20-7-SS	1-1/4-7	2-1/16	0.828	2.295	0.500	1/4-28
TCL-20-12-F	TCL-20-12-SS	1-1/4-12	2-1/16	0.828	2.295	0.500	1/4-28
TCL-22-12-F	TCL-22-12-SS	1-3/8-12	2-1/4	0.922	2.465	0.563	1/4-28
TCL-24-12-F	TCL-24-12-SS	1-1/2-12	2-3/8	0.984	2.578	0.563	1/4-28
TCL-28-16-F	TCL-28-16-SS	1-3/4-16	2-3/4	1.125	3.046	0.688	5/16-24
TCL-32-12-F	TCL-32-12-SS	2-12	3	1.250	3.273	0.688	5/16-24
TCL-36-12-F	TCL-36-12-SS	2-1/4-12	3-1/4	1.375	3.504	0.750	5/16-24

BLACK OXIDE STEEL	STAINLESS STEEL	BORE B	OUTER DIAM. OD (mm)	SCREW LOCATION R (mm)	CLEARANCE DIAM. C (mm) MAX	WIDTH W (mm)	FORGED CLAMP SCREW
MTCL-4-0.7-F	MTCL-4-0.7-SS	M4x0.7	16	5.5	20.8	9	M3
MTCL-5-0.8-F	MTCL-5-0.8-SS	M5x0.8	16	5.5	20.8	9	M3
MTCL-6-1-F	MTCL-6-1-SS	M6x1	16	5.5	20.8	9	M3
MTCL-8-1.25-F	MTCL-8-1.25-SS	M8x1.25	18	6.5	22.4	9	M3
MTCL-10-1.5-F	MTCL-10-1.5-SS	M10x1.5	24	8.5	26.3	9	M3
MTCL-12-1.75-F	MTCL-12-1.75-SS	M12x1.75	28	10.0	32.0	11	M4
MTCL-16-2-F	MTCL-16-2-SS	M16x2	34	12.5	39.3	13	M5
MTCL-20-2.5-F	MTCL-20-2.5-SS	M20x2.5	40	14.7	47.4	15	M6
MTCL-24-3-F	MTCL-24-3-SS	M24x3	45	29.5	52.1	15	M6
MTCL-30-3.5-F	MTCL-30-3.5-SS	M30x3.5	54	21.5	59.2	15	M6

Note: Sizes TCL-28 through TCL-36 do not have backslot.

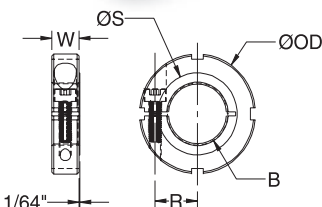

PART NO.	INDUSTRY STANDARD	LOCKNUT THREADS B	OUTER DIAM. OD (in)	BEARING FACE DIAM. S (in)	SCREW LOC. R (in)	WIDTH W (in)	FORGED CLAMP SCREW
TCN-00-F	-00	0.391-32	15/16	5/8	0.310	0.344	M3
TCN-01-F	-01	0.469-32	1-1/8	23/32	0.380	0.344	M3
TCN-02-F	-02	0.586-32	1-5/16	13/16	0.450	0.375	M4
TCN-03-F	-03	0.664-32	1-1/2	15/16	0.500	0.438	M5
TCN-04-F	-04	0.781-32	1-5/8	1-1/8	0.570	0.438	M5
TCN-05-F	-05	0.969-32	1-7/8	1-9/32	0.680	0.438	M5
TCN-06-F	-06	1.173-18	2	1-1/2	0.770	0.500	M5
TCN-07-F	-07	1.376-18	2-1/4	1-13/16	0.880	0.500	M5
TCN-08-F	-08	1.563-18	2-7/16	2	0.970	0.500	M5

- Does not mar shaft.
- Single point faced.
- Balanced styles available.
- Width tolerance:
+.003" / -.010"
- Bearing Face Max. TIR:
.0005" for 00-06,
.0010" for 07-08

For engineering and warranty/disclaimer information, see pp. 3 and 19 or www.ruland.com

ONE-PIECE CLAMP STYLE COLLAR

METRIC DIMENSION SERIES

MCL

PART NUMBER						SPECIFICATIONS					
BLACK OXIDE STEEL	ZINC PLATED STEEL	ALUMINUM	STAINLESS STEEL	316 STAINLESS STEEL	PLASTIC	BORE B (mm)	OUTER DIAM. OD (mm)	SCREW LOCATION R (mm)	CLEARANCE DIAMETER C (mm) MAX	WIDTH W (mm)	FORGED CLAMP SCREW
MCL-3-F	MCL-3-FZ	MCL-3-A	MCL-3-SS			3	16	5.51	20.8	9	M3
MCL-4-F	MCL-4-FZ	MCL-4-A	MCL-4-SS	MCL-4-ST	MCL-4-P	4	16	5.51	20.8	9	M3
MCL-5-F	MCL-5-FZ	MCL-5-A	MCL-5-SS	MCL-5-ST	MCL-5-P	5	16	5.51	20.8	9	M3
MCL-6-F	MCL-6-FZ	MCL-6-A	MCL-6-SS	MCL-6-ST	MCL-6-P	6	16	5.51	20.8	9	M3
MCL-7-F	MCL-7-FZ	MCL-7-A	MCL-7-SS			7	18	6.50	22.4	9	M3
MCL-8-F	MCL-8-FZ	MCL-8-A	MCL-8-SS	MCL-8-ST	MCL-8-P	8	18	6.50	22.4	9	M3
MCL-9-F	MCL-9-FZ	MCL-9-A	MCL-9-SS			9	24	8.51	26.3	9	M3
MCL-10-F	MCL-10-FZ	MCL-10-A	MCL-10-SS	MCL-10-ST	MCL-10-P	10	24	8.51	26.3	9	M3
MCL-11-F	MCL-11-FZ	MCL-11-A	MCL-11-SS			11	28	10.01	32.0	11	M4
MCL-12-F	MCL-12-FZ	MCL-12-A	MCL-12-SS	MCL-12-ST	MCL-12-P	12	28	10.01	32.0	11	M4
MCL-13-F	MCL-13-FZ	MCL-13-A	MCL-13-SS			13	30	11.00	33.7	11	M4
MCL-14-F	MCL-14-FZ	MCL-14-A	MCL-14-SS	MCL-14-ST	MCL-14-P	14	30	11.00	33.7	11	M4
MCL-15-F	MCL-15-FZ	MCL-15-A	MCL-15-SS	MCL-15-ST	MCL-15-P	15	34	12.50	39.3	13	M5
MCL-16-F	MCL-16-FZ	MCL-16-A	MCL-16-SS	MCL-16-ST	MCL-16-P	16	34	12.50	39.3	13	M5
MCL-17-F	MCL-17-FZ	MCL-17-A	MCL-17-SS			17	36	13.49	41.1	13	M5
MCL-18-F	MCL-18-FZ	MCL-18-A	MCL-18-SS			18	36	13.49	41.1	13	M5
MCL-19-F	MCL-19-FZ	MCL-19-A	MCL-19-SS			19	40	14.73	47.4	15	M6
MCL-20-F	MCL-20-FZ	MCL-20-A	MCL-20-SS	MCL-20-ST	MCL-20-P	20	40	14.73	47.4	15	M6
MCL-21-F	MCL-21-FZ	MCL-21-A	MCL-21-SS			21	42	16.00	49.5	15	M6
MCL-22-F	MCL-22-FZ	MCL-22-A	MCL-22-SS		MCL-22-P	22	42	16.00	49.5	15	M6
MCL-23-F	MCL-23-FZ	MCL-23-A	MCL-23-SS			23	45	17.50	52.1	15	M6
MCL-24-F	MCL-24-FZ	MCL-24-A	MCL-24-SS			24	45	17.50	52.1	15	M6
MCL-25-F	MCL-25-FZ	MCL-25-A	MCL-25-SS	MCL-25-ST	MCL-25-P	25	45	17.50	52.1	15	M6
MCL-26-F	MCL-26-FZ	MCL-26-A	MCL-26-SS			26	48	19.00	54.7	15	M6
MCL-28-F	MCL-28-FZ	MCL-28-A	MCL-28-SS		MCL-28-P	28	48	19.00	54.7	15	M6
MCL-30-F	MCL-30-FZ	MCL-30-A	MCL-30-SS	MCL-30-ST	MCL-30-P	30	54	21.49	59.2	15	M6
MCL-32-F	MCL-32-FZ	MCL-32-A	MCL-32-SS			32	54	21.49	59.2	15	M6
MCL-34-F	MCL-34-FZ	MCL-34-A	MCL-34-SS			34	57	23.24	62.4	15	M6
MCL-35-F	MCL-35-FZ	MCL-35-A	MCL-35-SS			35	57	23.24	62.4	15	M6
MCL-36-F	MCL-36-FZ	MCL-36-A	MCL-36-SS			36	57	23.24	62.4	15	M6
MCL-38-F	MCL-38-FZ	MCL-38-A	MCL-38-SS			38	60	24.99	65.6	15	M6
MCL-40-F	MCL-40-FZ	MCL-40-A	MCL-40-SS	MCL-40-ST		40	60	24.99	65.6	15	M6
MCL-42-F	MCL-42-FZ	MCL-42-A	MCL-42-SS			42	73	29.49	80.1	19	M8
MCL-45-F	MCL-45-FZ	MCL-45-A	MCL-45-SS			45	73	29.49	80.1	19	M8
MCL-48-F	MCL-48-FZ	MCL-48-A	MCL-48-SS			48	78	32.00	84.7	19	M8
MCL-50-F	MCL-50-FZ	MCL-50-A	MCL-50-SS	MCL-50-ST		50	78	32.00	84.7	19	M8
MCL-54-F		MCL-54-SS				54	82	34.24	88.8	19	M8
MCL-55-F		MCL-55-SS				55	82	34.24	88.8	19	M8
MCL-60-F		MCL-60-SS				60	88	37.01	94.0	19	M8
MCL-65-F		MCL-65-SS				65	93	39.50	99.8	19	M8
MCL-70-F		MCL-70-SS				70	98	42.01	104.5	19	M8
MCL-75-F		MCL-75-SS				75	103	44.50	109.1	19	M8
MCL-80-F		MCL-80-SS				80	108	46.99	113.8	19	M8

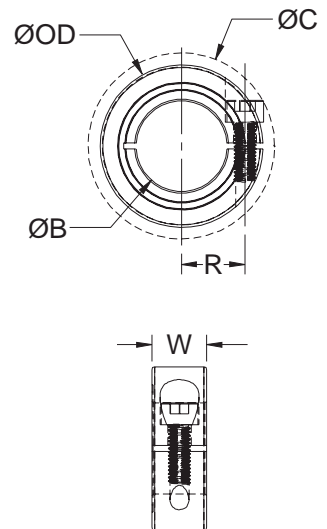

Note: Sizes MCL-40 through MCL-80 do not have backslot.

- Does not mar the shaft.
- Single point faced.
- Balanced versions available.
- Width tolerance: +.076 mm
-.254 mm
- Bore tolerance: +.050 mm
+.012 mm

For engineering and warranty/disclaimer information, see pp. 3 and 19 or www.ruland.com

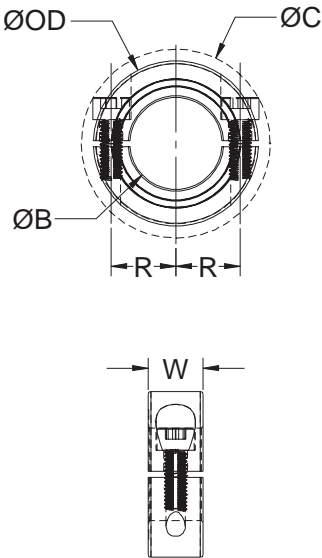

PART NUMBER						SPECIFICATIONS					
BLACK OXIDE STEEL	ZINC PLATED STEEL	ALUMINUM	STAINLESS STEEL	316 STAINLESS STEEL	PLASTIC	BORE B (mm)	OUTER DIAM. OD (mm)	SCREW LOCATION R (mm)	CLEARANCE DIAMETER (mm) MAX	WIDTH W (mm)	FORGED CLAMP SCREW
MSP-3-F	MSP-3-FZ	MSP-3-A	MSP-3-SS			3	16	5.51	20.8	9	M3
MSP-4-F	MSP-4-FZ	MSP-4-A	MSP-4-SS	MSP-4-ST	MSP-4-P	4	16	5.51	20.8	9	M3
MSP-5-F	MSP-5-FZ	MSP-5-A	MSP-5-SS	MSP-5-ST	MSP-5-P	5	16	5.51	20.8	9	M3
MSP-6-F	MSP-6-FZ	MSP-6-A	MSP-6-SS	MSP-6-ST	MSP-6-P	6	16	5.51	20.8	9	M3
MSP-7-F	MSP-7-FZ	MSP-7-A	MSP-7-SS			7	18	6.50	22.4	9	M3
MSP-8-F	MSP-8-FZ	MSP-8-A	MSP-8-SS	MSP-8-ST	MSP-8-P	8	18	6.50	22.4	9	M3
MSP-9-F	MSP-9-FZ	MSP-9-A	MSP-9-SS			9	24	8.51	26.3	9	M3
MSP-10-F	MSP-10-FZ	MSP-10-A	MSP-10-SS	MSP-10-ST	MSP-10-P	10	24	8.51	26.3	9	M3
MSP-11-F	MSP-11-FZ	MSP-11-A	MSP-11-SS			11	28	10.01	32.0	11	M4
MSP-12-F	MSP-12-FZ	MSP-12-A	MSP-12-SS	MSP-12-ST	MSP-12-P	12	28	10.01	32.0	11	M4
MSP-13-F	MSP-13-FZ	MSP-13-A	MSP-13-SS			13	30	11.00	33.7	11	M4
MSP-14-F	MSP-14-FZ	MSP-14-A	MSP-14-SS	MSP-14-ST	MSP-14-P	14	30	11.00	33.7	11	M4
MSP-15-F	MSP-15-FZ	MSP-15-A	MSP-15-SS	MSP-15-ST	MSP-15-P	15	34	12.50	39.3	13	M5
MSP-16-F	MSP-16-FZ	MSP-16-A	MSP-16-SS	MSP-16-ST	MSP-16-P	16	34	12.50	39.3	13	M5
MSP-17-F	MSP-17-FZ	MSP-17-A	MSP-17-SS			17	36	13.49	41.1	13	M5
MSP-18-F	MSP-18-FZ	MSP-18-A	MSP-18-SS			18	36	13.49	41.1	13	M5
MSP-19-F	MSP-19-FZ	MSP-19-A	MSP-19-SS			19	40	14.73	47.4	15	M6
MSP-20-F	MSP-20-FZ	MSP-20-A	MSP-20-SS	MSP-20-ST	MSP-20-P	20	40	14.73	47.4	15	M6
MSP-21-F	MSP-21-FZ	MSP-21-A	MSP-21-SS			21	42	16.00	49.5	15	M6
MSP-22-F	MSP-22-FZ	MSP-22-A	MSP-22-SS		MSP-22-P	22	42	16.00	49.5	15	M6
MSP-23-F	MSP-23-FZ	MSP-23-A	MSP-23-SS			23	45	17.50	52.1	15	M6
MSP-24-F	MSP-24-FZ	MSP-24-A	MSP-24-SS			24	45	17.50	52.1	15	M6
MSP-25-F	MSP-25-FZ	MSP-25-A	MSP-25-SS	MSP-25-ST	MSP-25-P	25	45	17.50	52.1	15	M6
MSP-26-F	MSP-26-FZ	MSP-26-A	MSP-26-SS			26	48	19.00	54.7	15	M6
MSP-28-F	MSP-28-FZ	MSP-28-A	MSP-28-SS		MSP-28-P	28	48	19.00	54.7	15	M6
MSP-30-F	MSP-30-FZ	MSP-30-A	MSP-30-SS	MSP-30-ST	MSP-30-P	30	54	21.49	59.2	15	M6
MSP-32-F	MSP-32-FZ	MSP-32-A	MSP-32-SS			32	54	21.49	59.2	15	M6
MSP-34-F	MSP-34-FZ	MSP-34-A	MSP-34-SS			34	57	23.24	62.4	15	M6
MSP-35-F	MSP-35-FZ	MSP-35-A	MSP-35-SS			35	57	23.24	62.4	15	M6
MSP-36-F	MSP-36-FZ	MSP-36-A	MSP-36-SS			36	57	23.24	62.4	15	M6
MSP-38-F	MSP-38-FZ	MSP-38-A	MSP-38-SS			38	60	24.99	65.6	15	M6
MSP-40-F	MSP-40-FZ	MSP-40-A	MSP-40-SS	MSP-40-ST		40	60	24.99	65.6	15	M6
MSP-42-F	MSP-42-FZ	MSP-42-A	MSP-42-SS			42	73	29.49	80.1	19	M8
MSP-45-F	MSP-45-FZ	MSP-45-A	MSP-45-SS			45	73	29.49	80.1	19	M8
MSP-48-F	MSP-48-FZ	MSP-48-A	MSP-48-SS			48	78	32.00	84.7	19	M8
MSP-50-F	MSP-50-FZ	MSP-50-A	MSP-50-SS	MSP-50-ST		50	78	32.00	84.7	19	M8
MSP-54-F		MSP-54-SS				54	82	34.24	88.8	19	M8
MSP-55-F		MSP-55-SS				55	82	34.24	88.8	19	M8
MSP-60-F		MSP-60-SS				60	88	37.01	94.0	19	M8
MSP-65-F		MSP-65-SS				65	93	39.50	99.8	19	M8
MSP-70-F		MSP-70-SS				70	98	42.01	104.5	19	M8
MSP-75-F		MSP-75-SS				75	103	44.50	109.1	19	M8
MSP-80-F		MSP-80-SS				80	108	46.99	113.8	19	M8

- Does not mar the shaft.
- Single point faced.
- Available with keyways.
- Opposing screws available.
- Width tolerance: +.076 mm
-.254 mm
- Bore tolerance: +.050 mm
+.012 mm

For engineering and warranty/disclaimer information, see pp. 3 and 19 or www.ruland.com

ONE-PIECE CLAMP SHAFT COLLAR INTERNATIONAL SERIES

TWO-PIECE CLAMP SHAFT COLLAR INTERNATIONAL SERIES

MCL
MSP

PART NUMBER			SPECIFICATIONS						
STEEL	ANODIZED ALUMINUM	STAINLESS STEEL	BORE B (in)	BORE B (mm)	OUTER DIAMETER OD (mm)	SCREW LOCATION R (mm)	CLEARANCE DIAMETER C (mm) MAX	WIDTH W (mm)	FORGED CLAMP SCREW
MCL-4E-F	MCL-4E-AN	MCL-4E-SS	.2500	6.35	18	6.50	22.4	9	M3
MCL-5E-F	MCL-5E-AN	MCL-5E-SS	.3125	7.94	18	6.50	22.4	9	M3
MCL-6E-F	MCL-6E-AN	MCL-6E-SS	.3750	9.53	24	8.51	26.3	9	M3
MCL-7E-F	MCL-7E-AN	MCL-7E-SS	.4375	11.11	28	10.01	32.0	11	M4
MCL-8E-F	MCL-8E-AN	MCL-8E-SS	.5000	12.70	30	11.00	33.7	11	M4
MCL-10E-F	MCL-10E-AN	MCL-10E-SS	.6250	15.88	34	12.50	39.3	13	M5
MCL-12E-F	MCL-12E-AN	MCL-12E-SS	.7500	19.05	40	14.73	47.4	15	M6
MCL-14E-F	MCL-14E-AN	MCL-14E-SS	.8750	22.23	42	16.00	49.5	15	M6
MCL-15E-F	MCL-15E-AN	MCL-15E-SS	.9375	23.81	45	17.50	52.1	15	M6
MCL-16E-F	MCL-16E-AN	MCL-16E-SS	1.0000	25.40	45	17.50	52.1	15	M6
MCL-18E-F	MCL-18E-AN	MCL-18E-SS	1.1250	28.58	48	19.00	54.7	15	M6
MCL-20E-F	MCL-20E-AN	MCL-20E-SS	1.2500	31.75	54	21.49	59.2	15	M6
MCL-22E-F	MCL-22E-AN	MCL-22E-SS	1.3750	34.93	57	23.24	62.4	15	M6
MCL-23E-F	MCL-23E-AN	MCL-23E-SS	1.4375	36.51	60	24.99	65.6	15	M6
MCL-24E-F	MCL-24E-AN	MCL-24E-SS	1.5000	38.10	60	24.99	65.6	15	M6
MCL-28E-F	MCL-28E-AN	MCL-28E-SS	1.7500	44.45	73	29.49	80.1	19	M8
MCL-31E-F	MCL-31E-AN	MCL-31E-SS	1.9375	49.21	78	32.00	84.7	19	M8
MCL-32E-F	MCL-32E-AN	MCL-32E-SS	2.0000	50.80	82	34.24	88.8	19	M8
MCL-35E-F	MCL-35E-AN	MCL-35E-SS	2.1875	55.56	88	37.01	94.0	19	M8
MCL-36E-F	MCL-36E-AN	MCL-36E-SS	2.2500	57.15	88	37.01	94.0	19	M8
MCL-39E-F	MCL-39E-AN	MCL-39E-SS	2.4375	61.91	93	39.50	99.8	19	M8
MCL-40E-F	MCL-40E-AN	MCL-40E-SS	2.5000	63.50	93	39.50	99.8	19	M8
MCL-47E-F	MCL-47E-AN	MCL-47E-SS	2.9375	74.61	103	44.50	109.1	19	M8
MCL-48E-F	MCL-48E-AN	MCL-48E-SS	3.0000	76.20	108	46.99	113.8	19	M8

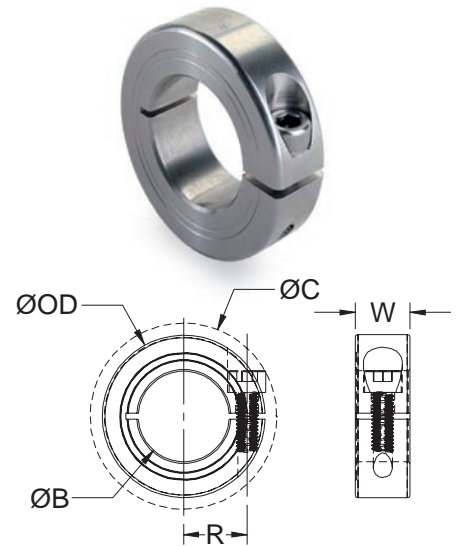

- Does not mar the shaft.
- Single point faced.
- Balanced versions available.
- Width tolerance: +.076 mm
-.254 mm
- Bore tolerance: +.050 mm
+.012 mm

PART NUMBER			SPECIFICATIONS						
STEEL	ANODIZED ALUMINUM	STAINLESS STEEL	BORE B (in)	BORE B (mm)	OUTER DIAMETER OD (mm)	SCREW LOCATION R (mm)	CLEARANCE DIAMETER C (mm) MAX	WIDTH W (mm)	FORGED CLAMP SCREW
MSP-4E-F	MSP-4E-AN	MSP-4E-SS	.2500	6.35	18	6.50	22.4	9	M3
MSP-5E-F	MSP-5E-AN	MSP-5E-SS	.3125	7.94	18	6.50	22.4	9	M3
MSP-6E-F	MSP-6E-AN	MSP-6E-SS	.3750	9.53	24	8.51	26.3	9	M3
MSP-7E-F	MSP-7E-AN	MSP-7E-SS	.4375	11.11	28	10.01	32.0	11	M4
MSP-8E-F	MSP-8E-AN	MSP-8E-SS	.5000	12.70	30	11.00	33.7	11	M4
MSP-10E-F	MSP-10E-AN	MSP-10E-SS	.6250	15.88	34	12.50	39.3	13	M5
MSP-12E-F	MSP-12E-AN	MSP-12E-SS	.7500	19.05	40	14.73	47.4	15	M6
MSP-14E-F	MSP-14E-AN	MSP-14E-SS	.8750	22.23	42	16.00	49.5	15	M6
MSP-15E-F	MSP-15E-AN	MSP-15E-SS	.9375	23.81	45	17.50	52.1	15	M6
MSP-16E-F	MSP-16E-AN	MSP-16E-SS	1.0000	25.40	45	17.50	52.1	15	M6
MSP-18E-F	MSP-18E-AN	MSP-18E-SS	1.1250	28.58	48	19.00	54.7	15	M6
MSP-20E-F	MSP-20E-AN	MSP-20E-SS	1.2500	31.75	54	21.49	59.2	15	M6
MSP-22E-F	MSP-22E-AN	MSP-22E-SS	1.3750	34.93	57	23.24	62.4	15	M6
MSP-23E-F	MSP-23E-AN	MSP-23E-SS	1.4375	36.51	60	24.99	65.6	15	M6
MSP-24E-F	MSP-24E-AN	MSP-24E-SS	1.5000	38.10	60	24.99	65.6	15	M6
MSP-28E-F	MSP-28E-AN	MSP-28E-SS	1.7500	44.45	73	29.49	80.1	19	M8
MSP-31E-F	MSP-31E-AN	MSP-31E-SS	1.9375	49.21	78	32.00	84.7	19	M8
MSP-32E-F	MSP-32E-AN	MSP-32E-SS	2.0000	50.80	82	34.24	88.8	19	M8
MSP-35E-F	MSP-35E-AN	MSP-35E-SS	2.1875	55.56	88	37.01	94.0	19	M8
MSP-36E-F	MSP-36E-AN	MSP-36E-SS	2.2500	57.15	88	37.01	94.0	19	M8
MSP-39E-F	MSP-39E-AN	MSP-39E-SS	2.4375	61.91	93	39.50	99.8	19	M8
MSP-40E-F	MSP-40E-AN	MSP-40E-SS	2.5000	63.50	93	39.50	99.8	19	M8
MSP-47E-F	MSP-47E-AN	MSP-47E-SS	2.9375	74.61	103	44.50	109.1	19	M8
MSP-48E-F	MSP-48E-AN	MSP-48E-SS	3.0000	76.20	108	46.99	113.8	19	M8

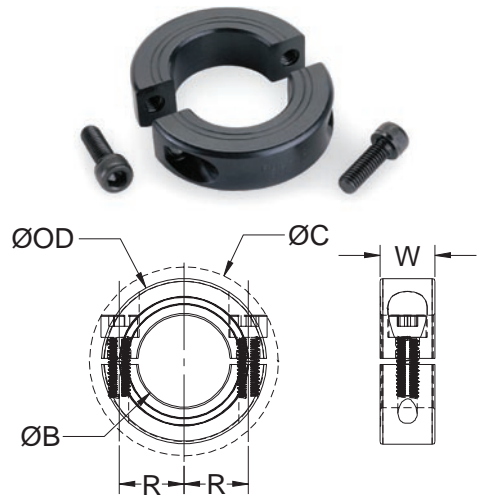

- Does not mar the shaft.
- Single point faced.
- Available with keyways.
- Opposing screws available.
- Width tolerance: +.076 mm
-.254 mm
- Bore tolerance: +.050 mm
+.012 mm

For engineering and warranty/disclaimer information, see pp. 3 and 19 or www.ruland.com

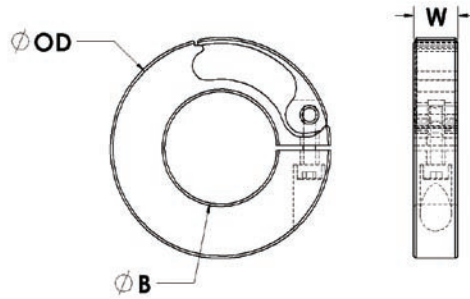

- Does not mar the shaft
- No tools required
- Designed for quick adjustments
- Made from aircraft quality aluminum
- Width tolerance:
QCL +.003"/-.010"
MQCL +.076 mm/-.254 mm
- Bore tolerance:
QCL +.002"/+.0005"
MQCL +.050 mm/+.012 mm

PART NUMBER	SPECIFICATIONS				
	BORE B (in)	OUTER DIAM. OD (mm)	WIDTH W (mm)	AXIAL LOAD (lbs)	SCREW TORQUE (in/lbs)
ANODIZED ALUMINUM					
QCL-6-A	0.375	38	10	35	4
QCL-8-A	0.500	38	10	40	4
QCL-10 -A	0.625	38	10	60	4
QCL-12 -A	0.750	50	13	70	6
QCL-16 -A	1.000	50	13	90	6
QCL-18 -A	1.125	50	13	100	6
QCL-20 -A	1.250	75	15	105	13
QCL-22-A	1.375	75	15	110	13
QCL-24-A	1.500	75	15	120	13
ANODIZED ALUMINUM	BORE B (mm)	OUTER DIAM. OD (mm)	WIDTH W (mm)	AXIAL LOAD (N)	SCREW TORQUE (Nm)
MQCL-8-A	8	38	10	133	0.45
MQCL-10-A	10	38	10	155	0.45
MQCL-12-A	12	38	10	162	0.45
MQCL-14-A	14	38	10	180	0.45
MQCL-15-A	15	38	10	220	0.45
MQCL-16-A	16	38	10	266	0.45
MQCL-20-A	20	50	13	311	0.45
MQCL-25-A	25	50	13	400	0.678
MQCL-28-A	28	50	13	435	0.678
MQCL-30-A	30	50	13	450	0.678
MQCL-32-A	32	75	15	467	1.47
MQCL-35-A	35	75	15	489	1.47

For engineering and warranty/disclaimer information, see pp. 3 and 19 or www.ruland.com

DOUBLE-WIDE ONE-PIECE CLAMP STYLE COLLAR DOUBLE-WIDE TWO-PIECE CLAMP STYLE COLLAR

**WCL
WSP**

WCL

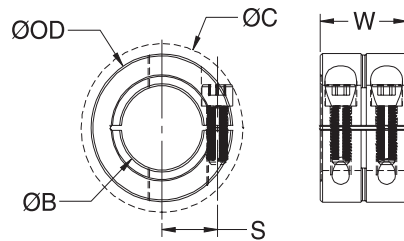

WSP

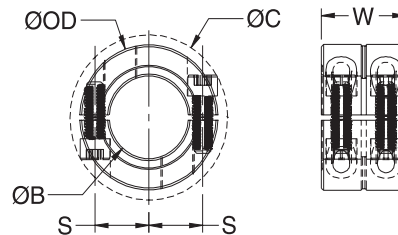

PART NUMBER			SPECIFICATIONS					
BLACK OXIDE STEEL	ALUMINUM	STAINLESS STEEL	BORE B (in)	OUTER DIAM. OD (in)	SCREW LOCATION S (in)	CLEARANCE DIAMETER C (in) MAX	WIDTH W (in)	FORGED CLAMP SCREW
WCL-2-F	WCL-2-A	WCL-2-SS	0.125	5/8	0.210	0.773	5/8	#4-40
WCL-3-F	WCL-3-A	WCL-3-SS	0.188	5/8	0.210	0.773	5/8	#4-40
WCL-4-F	WCL-4-A	WCL-4-SS	0.250	5/8	0.210	0.773	5/8	#4-40
WCL-5-F	WCL-5-A	WCL-5-SS	0.313	11/16	0.250	0.838	5/8	#4-40
WCL-6-F	WCL-6-A	WCL-6-SS	0.375	7/8	0.313	1.027	3/4	#6-32
WCL-8-F	WCL-8-A	WCL-8-SS	0.500	1-1/8	0.406	1.281	7/8	#8-32
WCL-10-F		WCL-10-SS	0.625	1-5/16	0.479	1.500	15/16	#10-32
WCL-12-F		WCL-12-SS	0.750	1-1/2	0.545	1.808	1-1/16	1/4-28
WCL-14-F		WCL-14-SS	0.875	1-5/8	0.610	1.916	1-1/16	1/4-28
WCL-16-F		WCL-16-SS	1.000	1-3/4	0.678	2.032	1-1/16	1/4-28
WSP-2-F		WSP-2-SS	0.125	5/8	0.210	0.773	5/8	#4-40
WSP-3-F		WSP-3-SS	0.188	5/8	0.210	0.773	5/8	#4-40
WSP-4-F		WSP-4-SS	0.250	5/8	0.210	0.773	5/8	#4-40
WSP-5-F		WSP-5-SS	0.313	11/16	0.250	0.838	5/8	#4-40
WSP-6-F		WSP-6-SS	0.375	7/8	0.313	1.027	3/4	#6-32
WSP-8-F		WSP-8-SS	0.500	1-1/8	0.406	1.281	7/8	#8-32
WSP-10-F		WSP-10-SS	0.625	1-5/16	0.479	1.500	15/16	#10-32
WSP-12-F		WSP-12-SS	0.750	1-1/2	0.545	1.808	1-1/16	1/4-28
WSP-14-F		WSP-14-SS	0.875	1-5/8	0.610	1.916	1-1/16	1/4-28
WSP-16-F		WSP-16-SS	1.000	1-3/4	0.678	2.032	1-1/16	1/4-28

- Does not mar the shaft.
- Single point faced.
- Opposing hardware on 2-piece styles for balance.
- Excellent for high axial loads.
- Transmit torque in confined spaces.
- Step bores available.
- Width tolerance: +.003" - .010"
- Bore tolerance: +.002" +.0005"

For engineering and warranty/disclaimer information, see pp. 3 and 19 or www.ruland.com

MWCL

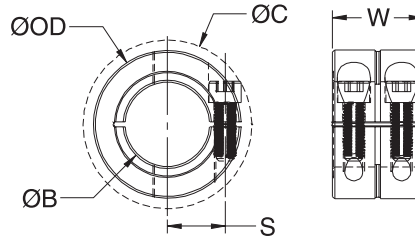

MWSP

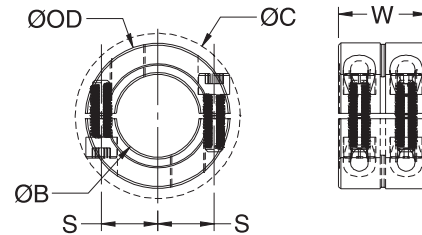

PART NUMBER			SPECIFICATIONS					
BLACK OXIDE STEEL	ALUMINUM	STAINLESS STEEL	BORE B (mm)	OUTER DIAM. OD (mm)	SCREW LOCATION S (mm)	CLEARANCE DIAMETER C (mm)	WIDTH W (mm)	FORGED CLAMP SCREW
MWCL-6-F	MWCL-6-A	MWCL-6-SS	6	16	5.51	20.8	20	M3
MWCL-8-F	MWCL-8-A	MWCL-8-SS	8	18	6.5	22.4	20	M3
MWCL-10-F	MWCL-10-A	MWCL-10-SS	10	24	8.51	26.3	20	M3
MWCL-12-F	MWCL-12-A	MWCL-12-SS	12	28	10.01	32	24	M4
MWCL-16-F		MWCL-16-SS	16	34	12.5	39.3	29	M5
MWCL-20-F		MWCL-20-SS	20	40	14.73	47.4	33	M6
MWCL-25-F		MWCL-25-SS	25	45	17.5	52.1	33	M6
MWSP-6-F		MWSP-6-SS	6	16	5.51	20.8	20	M3
MWSP-8-F		MWSP-8-SS	8	18	6.5	22.4	20	M3
MWSP-10-F		MWSP-10-SS	10	24	8.51	26.3	20	M3
MWSP-12-F		MWSP-12-SS	12	28	10.01	32	24	M4
MWSP-16-F		MWSP-16-SS	16	34	12.5	39.3	29	M5
MWSP-20-F		MWSP-20-SS	20	40	14.73	47.4	33	M6
MWSP-25-F		MWSP-25-SS	25	45	17.5	52.1	33	M6

- Does not mar the shaft
- Single point faced
- Opposing hardware on 2-piece styles for balance
- Excellent for high axial loads
- Transmit torque in confined spaces
- Step bores available
- Width tolerance: +.076 mm
-.254 mm
- Bore tolerance: +.050 mm
+.012 mm
- Additional sizes available

For engineering and warranty/disclaimer information, see pp. 3 and 19 or www.ruland.com

ONE- AND TWO-PIECE RIGID COUPLINGS WITHOUT KEYWAY • INCH DIMENSION SERIES

**CLX
SPX**

CLX

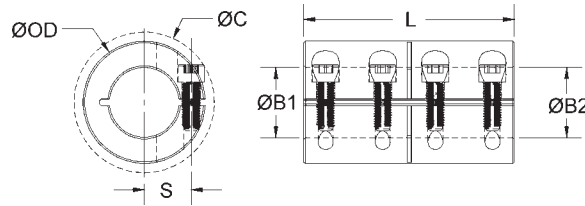

SPX

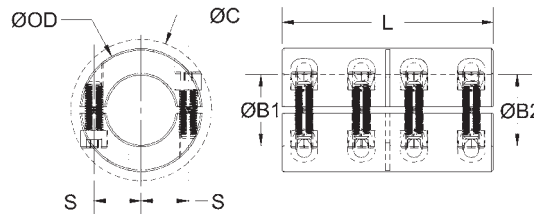

- Does not mar the shaft.
- Precision honed bore on straight bore couplings.
- 3-piece styles available.
- Nypatch® Anti-vibration hardware.
- Opposing hardware on 2-piece styles.
- Additional sizes available.
- Bore tolerance: +.002"
+.0005"
- Maximum speed: 4,000 rpm

PART NUMBER

SPECIFICATIONS

ONE-PIECE		TWO-PIECE			BORE B1 (in)	BORE B2 (in)	OUTER DIAM. OD (in)	SCREW LOCATION S (in)	CLEARANCE DIAMETER C (in) MAX	LENGTH L (in)	FORGED CLAMP SCREW
BLACK OXIDE STEEL	ALUMINUM	BLACK OXIDE STEEL	STAINLESS STEEL	STAINLESS STEEL							
CLX-2-2-F	CLX-2-2-A	CLX-2-2-SS	SPX-2-2-F	SPX-2-2-SS	0.125	0.125	1/2	0.150	0.578	13/16	#2-56
CLX-3-3-F	CLX-3-3-A	CLX-3-3-SS	SPX-3-3-F	SPX-3-3-SS	0.188	0.188	9/16	0.185	0.651	7/8	#2-56
CLX-4-3-F	CLX-4-3-A	CLX-4-3-SS	SPX-4-3-F	SPX-4-3-SS	0.250	0.188	5/8	0.219	0.815	1	#4-40
CLX-4-4-F	CLX-4-4-A	CLX-4-4-SS	SPX-4-4-F	SPX-4-4-SS	0.250	0.250	5/8	0.219	0.815	1	#4-40
CLX-6-4-F	CLX-6-4-A	CLX-6-4-SS	SPX-6-4-F	SPX-6-4-SS	0.375	0.250	7/8	0.313	1.033	1-3/8	#6-32
CLX-6-6-F	CLX-6-6-A	CLX-6-6-SS	SPX-6-6-F	SPX-6-6-SS	0.375	0.375	7/8	0.313	1.033	1-3/8	#6-32
CLX-8-6-F	CLX-8-6-A	CLX-8-6-SS	SPX-8-6-F	SPX-8-6-SS	0.500	0.375	1-1/8	0.430	1.328	1-3/4	#8-32
CLX-8-8-F	CLX-8-8-A	CLX-8-8-SS	SPX-8-8-F	SPX-8-8-SS	0.500	0.500	1-1/8	0.430	1.328	1-3/4	#8-32
CLX-10-8-F	CLX-10-8-A	CLX-10-8-SS	SPX-10-8-F	SPX-10-8-SS	0.625	0.500	1-5/16	0.484	1.514	2	#10-32
CLX-10-10-F	CLX-10-10-A	CLX-10-10-SS	SPX-10-10-F	SPX-10-10-SS	0.625	0.625	1-5/16	0.484	1.514	2	#10-32
CLX-12-8-F		CLX-12-8-SS	SPX-12-8-F	SPX-12-8-SS	0.750	0.500	1-1/2	0.545	1.842	2-1/4	1/4-28
CLX-12-10-F		CLX-12-10-SS	SPX-12-10-F	SPX-12-10-SS	0.750	0.625	1-1/2	0.545	1.842	2-1/4	1/4-28
CLX-12-12-F		CLX-12-12-SS	SPX-12-12-F	SPX-12-12-SS	0.750	0.750	1-1/2	0.545	1.842	2-1/4	1/4-28
CLX-14-10-F		CLX-14-10-SS	SPX-14-10-F	SPX-14-10-SS	0.875	0.625	1-5/8	0.600	1.932	2-1/2	1/4-28
CLX-14-14-F		CLX-14-14-SS	SPX-14-14-F	SPX-14-14-SS	0.875	0.875	1-5/8	0.600	1.932	2-1/2	1/4-28
CLX-16-8-F		CLX-16-8-SS	SPX-16-8-F	SPX-16-8-SS	1.000	0.500	1-3/4	0.670	2.049	3	1/4-28
CLX-16-12-F		CLX-16-12-SS	SPX-16-12-F	SPX-16-12-SS	1.000	0.750	1-3/4	0.670	2.049	3	1/4-28
CLX-16-16-F		CLX-16-16-SS	SPX-16-16-F	SPX-16-16-SS	1.000	1.000	1-3/4	0.670	2.049	3	1/4-28
CLX-18-16-F		CLX-18-16-SS	SPX-18-16-F	SPX-18-16-SS	1.125	1.000	1-7/8	0.748	2.182	3-1/8	1/4-28
CLX-18-18-F		CLX-18-18-SS	SPX-18-18-F	SPX-18-18-SS	1.125	1.125	1-7/8	0.748	2.182	3-1/8	1/4-28
CLX-19-19-F		CLX-19-19-SS	SPX-19-19-F	SPX-19-19-SS	1.188	1.188	2-1/16	0.807	2.242	3-1/4	1/4-28
CLX-20-16-F		CLX-20-16-SS	SPX-20-16-F	SPX-20-16-SS	1.250	1.000	2-1/16	0.807	2.286	3-1/4	1/4-28
CLX-20-20-F		CLX-20-20-SS	SPX-20-20-F	SPX-20-20-SS	1.250	1.250	2-1/16	0.807	2.286	3-1/4	1/4-28
CLX-22-16-F		CLX-22-16-SS	SPX-22-16-F	SPX-22-16-SS	1.375	1.000	2-1/2	0.986	2.772	3-5/8	5/16-24
CLX-22-22-F		CLX-22-22-SS	SPX-22-22-F	SPX-22-22-SS	1.375	1.375	2-1/2	0.986	2.772	3-5/8	5/16-24
CLX-23-23-F		CLX-23-23-SS	SPX-23-23-F	SPX-23-23-SS	1.438	1.438	2-5/8	1.050	2.840	3-7/8	5/16-24
CLX-24-16-F		CLX-24-16-SS	SPX-24-16-F	SPX-24-16-SS	1.500	1.000	2-5/8	1.050	2.886	3-7/8	5/16-24
CLX-24-24-F		CLX-24-24-SS	SPX-24-24-F	SPX-24-24-SS	1.500	1.500	2-5/8	1.050	2.886	3-7/8	5/16-24
CLX-28-28-F		CLX-28-28-SS	SPX-28-28-F	SPX-28-28-SS	1.750	1.750	3-1/8	1.305	3.365	4-1/2	3/8-24
CLX-31-31-F		CLX-31-31-SS	SPX-31-31-F	SPX-31-31-SS	1.938	1.938	3-3/8	1.391	3.657	4-7/8	3/8-24
CLX-32-32-F		CLX-32-32-SS	SPX-32-32-F	SPX-32-32-SS	2.000	2.000	3-3/8	1.391	3.717	4-7/8	3/8-24

For engineering and warranty/disclaimer information, see pp. 3 and 19 or www.ruland.com

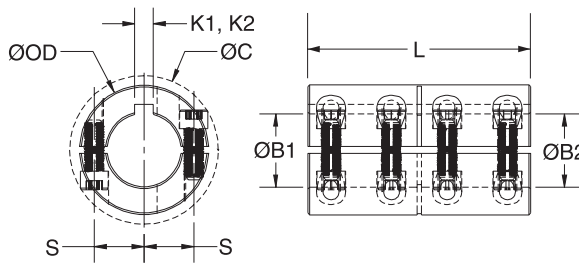
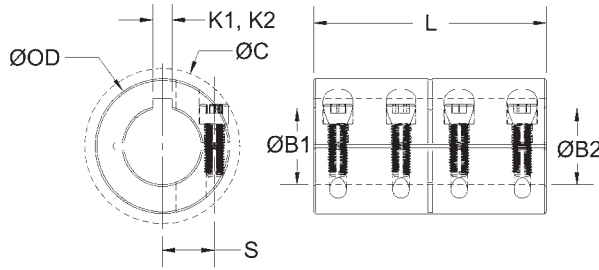
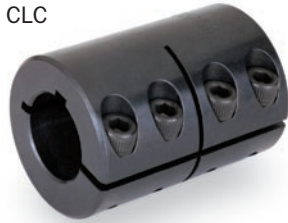

- Does not mar the shaft.
- Precision honed bore on straight bore couplings.
- 3-piece styles available.
- Nypatch® Anti-vibration hardware.
- Opposing hardware on 2-piece styles.
- Additional sizes available.
- Bore tolerance: +.002" +.0005"
- Maximum speed: 4,000 rpm

PART NUMBER

SPECIFICATIONS

PART NUMBER				SPECIFICATIONS									
ONE-PIECE		TWO-PIECE		BORE	BORE	OD	LENGTH	SCREW	CLEARANCE	KEYWAY	KEYWAY	FORGED	
BLACK OXIDE	STAINLESS	BLACK OXIDE	STAINLESS	B1 (in)	B2 (in)	(in)	L (in)	LOCATION	DIAMETER	K1 (in)	K2 (in)	CLAMP	
STEEL	STEEL	STEEL	STEEL					S (in)	C (in) MAX			SCREW	
		SPC-6-4-F	SPC-6-4-SS	0.375	0.250	7/8	1-3/8	0.313	1.033	3/32	N/A	#6-32	
CLC-6-6-F	CLC-6-6-SS	SPC-6-6-F	SPC-6-6-SS	0.375	0.375	7/8	1-3/8	0.313	1.033	3/32	3/32	#6-32	
		SPC-8-6-F	SPC-8-6-SS	0.500	0.375	1-1/8	1-3/4	0.430	1.328	1/8	3/32	#8-32	
CLC-8-8-F	CLC-8-8-SS	SPC-8-8-F	SPC-8-8-SS	0.500	0.500	1-1/8	1-3/4	0.430	1.328	1/8	1/8	#8-32	
		SPC-10-8-F	SPC-10-8-SS	0.625	0.500	1-5/16	2	0.484	1.514	3/16	1/8	#10-32	
CLC-10-10-F	CLC-10-10-SS	SPC-10-10-F	SPC-10-10-SS	0.625	0.625	1-5/16	2	0.484	1.514	3/16	3/16	#10-32	
		SPC-12-8-F	SPC-12-8-SS	0.750	0.500	1-1/2	2-1/4	0.545	1.842	3/16	1/8	1/4-28	
		SPC-12-10-F	SPC-12-10-SS	0.750	0.625	1-1/2	2-1/4	0.545	1.842	3/16	3/16	1/4-28	
CLC-12-12-F	CLC-12-12-SS	SPC-12-12-F	SPC-12-12-SS	0.750	0.750	1-1/2	2-1/4	0.545	1.842	3/16	3/16	1/4-28	
		SPC-14-10-F	SPC-14-10-SS	0.875	0.625	1-5/8	2-1/2	0.600	1.932	3/16	3/16	1/4-28	
CLC-14-14-F	CLC-14-14-SS	SPC-14-14-F	SPC-14-14-SS	0.875	0.875	1-5/8	2-1/2	0.600	1.932	3/16	3/16	1/4-28	
		SPC-16-8-F	SPC-16-8-SS	1.000	0.500	1-3/4	3	0.670	2.049	1/4	1/8	1/4-28	
		SPC-16-12-F	SPC-16-12-SS	1.000	0.750	1-3/4	3	0.670	2.049	1/4	3/16	1/4-28	
CLC-16-16-F	CLC-16-16-SS	SPC-16-16-F	SPC-16-16-SS	1.000	1.000	1-3/4	3	0.670	2.049	1/4	1/4	1/4-28	
		SPC-18-16-F	SPC-18-16-SS	1.125	1.000	1-7/8	3-1/8	0.748	2.182	1/4	1/4	1/4-28	
CLC-18-18-F	CLC-18-18-SS	SPC-18-18-F	SPC-18-18-SS	1.125	1.125	1-7/8	3-1/8	0.748	2.182	1/4	1/4	1/4-28	
CLC-19-19-F	CLC-19-19-SS	SPC-19-19-F	SPC-19-19-SS	1.188	1.188	2-1/16	3-1/4	0.807	2.242	1/4	1/4	1/4-28	
		SPC-20-16-F	SPC-20-16-SS	1.250	1.000	2-1/16	3-1/4	0.807	2.286	1/4	1/4	1/4-28	
CLC-20-20-F	CLC-20-20-SS	SPC-20-20-F	SPC-20-20-SS	1.250	1.250	2-1/16	3-1/4	0.807	2.286	1/4	1/4	1/4-28	
		SPC-22-16-F	SPC-22-16-SS	1.375	1.000	2-1/2	3-5/8	0.986	2.772	5/16	1/4	5/16-24	
CLC-22-22-F	CLC-22-22-SS	SPC-22-22-F	SPC-22-22-SS	1.375	1.375	2-1/2	3-5/8	0.986	2.772	5/16	5/16	5/16-24	
CLC-23-23-F	CLC-23-23-SS	SPC-23-23-F	SPC-23-23-SS	1.438	1.438	2-5/8	3-7/8	1.050	2.840	3/8	3/8	5/16-24	
		SPC-24-16-F	SPC-24-16-SS	1.500	1.000	2-5/8	3-7/8	1.050	2.886	3/8	1/4	5/16-24	
CLC-24-24-F	CLC-24-24-SS	SPC-24-24-F	SPC-24-24-SS	1.500	1.500	2-5/8	3-7/8	1.050	2.886	3/8	3/8	5/16-24	
CLC-28-28-F	CLC-28-28-SS	SPC-28-28-F	SPC-28-28-SS	1.750	1.750	3-1/8	4-1/2	1.305	3.365	3/8	3/8	3/8-24	
CLC-31-31-F	CLC-31-31-SS	SPC-31-31-F	SPC-31-31-SS	1.938	1.938	3-3/8	4-7/8	1.391	3.657	1/2	1/2	3/8-24	
CLC-32-32-F	CLC-32-32-SS	SPC-32-32-F	SPC-32-32-SS	2.000	2.000	3-3/8	4-7/8	1.391	3.717	1/2	1/2	3/8-24	

For engineering and warranty/disclaimer information, see pp. 3 and 19 or www.ruland.com

ONE- AND TWO-PIECE RIGID COUPLINGS WITHOUT OR WITH KEYWAY • METRIC DIMENSION SERIES

MCLX/MSPX MCLC/MSPC

MCLX

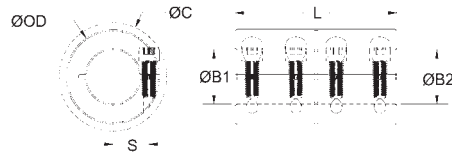

MCLC

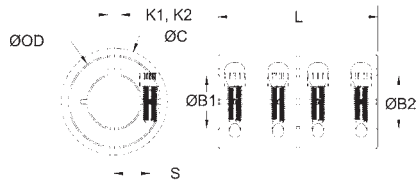

MSPX

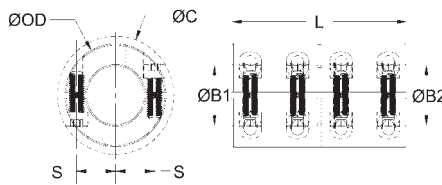

MSPC

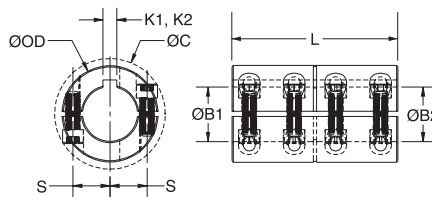

- Does not mar the shaft.
- Precision honed bore on straight bore couplings.
- 3-piece styles available.
- Nypatch® Anti-vibration hardware.
- Opposing hardware on 2-piece styles.
- Additional sizes available.
- Bore tolerance: +.050 mm
+.012 mm
- Maximum speed: 4,000 rpm

PART NUMBER

ONE-PIECE					TWO-PIECE					SPECIFICATIONS				
BLACK OXIDE STEEL	ALUMINUM	STAINLESS STEEL	BLACK OXIDE STEEL	STAINLESS STEEL	BORES B1, B2 (mm)	OD (mm)	LENGTH L (mm)	SCREW LOC. S (mm)	CLEARANCE DIAM. C (mm) MAX	KEYWAY K1, K2 (mm)	FORGED CLAMP SCREW			
MCLX-3-3-F	MCLX-3-3-A	MCLX-3-3-SS	MSPX-3-3-F	MSPX-3-3-SS	3	15	22	4.6	15.0		M2			
MCLX-4-4-F	MCLX-4-4-A	MCLX-4-4-SS	MSPX-4-4-F	MSPX-4-4-SS	4	15	22	4.6	15.0		M2			
MCLX-5-5-F	MCLX-5-5-A	MCLX-5-5-SS	MSPX-5-5-F	MSPX-5-5-SS	5	15	22	4.6	15.0		M2			
MCLX-6-6-F	MCLX-6-6-A	MCLX-6-6-SS	MSPX-6-6-F	MSPX-6-6-SS	6	18	30	5.9	21.5		M3			
MCLX-8-8-F	MCLX-8-8-A	MCLX-8-8-SS	MSPX-8-8-F	MSPX-8-8-SS	8	24	35	9.0	27.1		M3			
MCLX-10-10-F	MCLX-10-10-A	MCLX-10-10-SS	MSPX-10-10-F	MSPX-10-10-SS	10	29	45	10.6	33.0		M4			
MCLX-12-12-F	MCLX-12-12-A	MCLX-12-12-SS	MSPX-12-12-F	MSPX-12-12-SS	12	29	45	10.6	33.0		M4			
MCLX-14-14-F		MCLX-14-14-SS	MSPX-14-14-F	MSPX-14-14-SS	14	34	50	12.0	39.4		M5			
MCLX-15-15-F		MCLX-15-15-SS	MSPX-15-15-F	MSPX-15-15-SS	15	34	50	12.0	39.4		M5			
MCLX-16-16-F		MCLX-16-16-SS	MSPX-16-16-F	MSPX-16-16-SS	16	34	50	12.0	39.4		M5			
MCLX-20-20-F		MCLX-20-20-SS	MSPX-20-20-F	MSPX-20-20-SS	20	42	65	15.4	48.9		M6			
MCLX-25-25-F		MCLX-25-25-SS	MSPX-25-25-F	MSPX-25-25-SS	25	45	75	16.9	51.5		M6			
MCLX-30-30-F		MCLX-30-30-SS	MSPX-30-30-F	MSPX-30-30-SS	30	53	83	20.9	58.7		M6			
MCLX-35-35-F		MCLX-35-35-SS	MSPX-35-35-F	MSPX-35-35-SS	35	67	95	26.7	74.7		M8			
MCLX-40-40-F		MCLX-40-40-SS	MSPX-40-40-F	MSPX-40-40-SS	40	77	108	31.8	84.0		M8			
MCLX-50-50-F		MCLX-50-50-SS	MSPX-50-50-F	MSPX-50-50-SS	50	85	124	34.1	94.2		M10			
MCLC-6-6-F		MCLC-6-6-SS	MSPC-6-6-F	MSPC-6-6-SS	6	18	30	5.9	21.5	2	M3			
MCLC-8-8-F		MCLC-8-8-SS	MSPC-8-8-F	MSPC-8-8-SS	8	24	35	9.0	27.1	2	M3			
MCLC-10-10-F		MCLC-10-10-SS	MSPC-10-10-F	MSPC-10-10-SS	10	29	45	10.6	33.0	3	M4			
MCLC-12-12-F		MCLC-12-12-SS	MSPC-12-12-F	MSPC-12-12-SS	12	29	45	10.6	33.0	4	M4			
MCLC-14-14-F		MCLC-14-14-SS	MSPC-14-14-F	MSPC-14-14-SS	14	34	50	12.0	39.4	5	M5			
MCLC-15-15-F		MCLC-15-15-SS	MSPC-15-15-F	MSPC-15-15-SS	15	34	50	12.0	39.4	5	M5			
MCLC-16-16-F		MCLC-16-16-SS	MSPC-16-16-F	MSPC-16-16-SS	16	34	50	12.0	39.4	5	M5			
MCLC-20-20-F		MCLC-20-20-SS	MSPC-20-20-F	MSPC-20-20-SS	20	42	65	15.4	48.9	6	M6			
MCLC-25-25-F		MCLC-25-25-SS	MSPC-25-25-F	MSPC-25-25-SS	25	45	75	16.9	51.5	8	M6			
MCLC-30-30-F		MCLC-30-30-SS	MSPC-30-30-F	MSPC-30-30-SS	30	53	83	20.9	58.7	8	M6			
MCLC-35-35-F		MCLC-35-35-SS	MSPC-35-35-F	MSPC-35-35-SS	35	67	95	26.7	74.7	10	M8			
MCLC-40-40-F		MCLC-40-40-SS	MSPC-40-40-F	MSPC-40-40-SS	40	77	108	31.8	84.0	12	M8			
MCLC-50-50-F		MCLC-50-50-SS	MSPC-50-50-F	MSPC-50-50-SS	50	85	124	34.1	94.2	14	M10			

For engineering and warranty/disclaimer information, see pp. 3 and 19 or www.ruland.com

SCX / MSCX

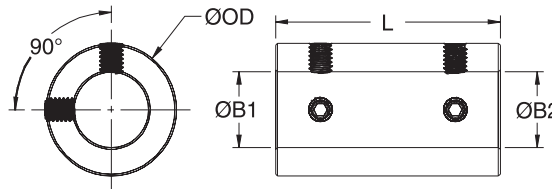

- Precision honed bore on straight bore couplings.
- Additional sizes available.
- Bore tolerance:
INCH SIZES: +.002"
 +.0005"
METRIC SIZES: +.050 mm
 +.012 mm
- Maximum speed: 4,000 rpm

SCC / MSCC

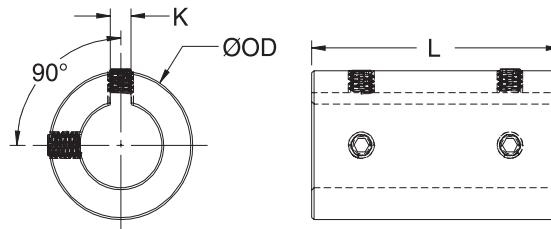

PART NUMBER				SPECIFICATIONS					
WITHOUT KEYWAY		WITH KEYWAY		BORE 1 (in)	BORE 2 (in)	OUTER DIAM. OD (in)	LENGTH L (in)	KEYWAY K (SCC ONLY) (in)	FORGED SOCKET SET SCREW
BLACK OXIDE STEEL	STAINLESS STEEL	BLACK OXIDE STEEL	STAINLESS STEEL						
SCX-4-4-F	SCX-4-4-SS			0.250	0.250	5/8	1	n/a	#10-32
SCX-6-6-F	SCX-6-6-SS	SCC-6-6-F	SCC-6-6-SS	0.375	0.375	7/8	1-3/8	3/32	1/4-20
SCX-8-8-F	SCX-8-8-SS	SCC-8-8-F	SCC-8-8-SS	0.500	0.500	1-1/8	1-3/4	1/8	1/4-20
SCX-10-10-F	SCX-10-10-SS	SCC-10-10-F	SCC-10-10-SS	0.625	0.625	1-5/16	2	3/16	5/16-18
SCX-12-12-F	SCX-12-12-SS	SCC-12-12-F	SCC-12-12-SS	0.750	0.750	1-1/2	2-1/4	3/16	5/16-18
SCX-14-14-F	SCX-14-14-SS	SCC-14-14-F	SCC-14-14-SS	0.875	0.875	1-5/8	2-1/2	3/16	5/16-18
SCX-16-16-F	SCX-16-16-SS	SCC-16-16-F	SCC-16-16-SS	1.000	1.000	1-3/4	3	1/4	5/16-18
SCX-18-18-F	SCX-18-18-SS	SCC-18-18-F	SCC-18-18-SS	1.125	1.125	1-7/8	3-1/8	1/4	3/8-16
SCX-20-20-F	SCX-20-20-SS	SCC-20-20-F	SCC-20-20-SS	1.250	1.250	2-1/16	3-1/4	1/4	3/8-16
SCX-22-22-F	SCX-22-22-SS	SCC-22-22-F	SCC-22-22-SS	1.375	1.375	2-1/2	3-5/8	5/16	3/8-16
SCX-24-24-F	SCX-24-24-SS	SCC-24-24-F	SCC-24-24-SS	1.500	1.500	2-5/8	3-7/8	3/8	3/8-16
SCX-28-28-F	SCX-28-28-SS	SCC-28-28-F	SCC-28-28-SS	1.750	1.750	3-1/8	4-1/2	3/8	1/2-13
SCX-32-32-F	SCX-32-32-SS	SCC-32-32-F	SCC-32-32-SS	2.000	2.000	3-3/8	4-7/8	1/2	1/2-13
WITHOUT KEYWAY		WITH KEYWAY		BORE 1 (mm)	BORE 2 (mm)	OUTER DIAM. OD (mm)	LENGTH L (mm)	KEYWAY K (MSCC ONLY) (mm)	FORGED SOCKET SET SCREW
BLACK OXIDE STEEL	STAINLESS STEEL	BLACK OXIDE STEEL	STAINLESS STEEL						
MSCX-6-6-F	MSCX-6-6-SS			6	6	18	30	2	M4
MSCX-8-8-F	MSCX-8-8-SS	MSCC-8-8-F	MSCC-8-8-SS	8	8	24	35	2	M4
MSCX-10-10-F	MSCX-10-10-SS	MSCC-10-10-F	MSCC-10-10-SS	10	10	29	45	3	M5
MSCX-12-12-F	MSCX-12-12-SS	MSCC-12-12-F	MSCC-12-12-SS	12	12	29	45	4	M6
MSCX-14-14-F	MSCX-14-14-SS	MSCC-14-14-F	MSCC-14-14-SS	14	14	34	50	5	M6
MSCX-16-16-F	MSCX-16-16-SS	MSCC-16-16-F	MSCC-16-16-SS	16	16	34	50	5	M6
MSCX-20-20-F	MSCX-20-20-SS	MSCC-20-20-F	MSCC-20-20-SS	20	20	42	65	6	M6
MSCX-25-25-F	MSCX-25-25-SS	MSCC-25-25-F	MSCC-25-25-SS	25	25	45	75	8	M8
MSCX-30-30-F	MSCX-30-30-SS	MSCC-30-30-F	MSCC-30-30-SS	30	30	53	83	8	M8
MSCX-35-35-F	MSCX-35-35-SS	MSCC-35-35-F	MSCC-35-35-SS	35	35	67	95	10	M8
MSCX-40-40-F	MSCX-40-40-SS	MSCC-40-40-F	MSCC-40-40-SS	40	40	77	108	12	M10
MSCX-50-50-F	MSCX-50-50-SS	MSCC-50-50-F	MSCC-50-50-SS	50	50	85	124	14	M10

For engineering and warranty/disclaimer information, see pp. 3 and 19 or www.ruland.com

All Products Are RoHS and REACH Compliant

Materials

Steel Products: 1215 Cold Drawn Bar.

Aluminum Products: 2024-T351 Extruded and Drawn Aluminum Bar.

Stainless Steel Products: Product part numbers ending in "SS": 18-8 (type 303) austenitic, non-magnetic bar. Product part numbers ending in "ST": type 316L.

Plastic: Acetal (white)

Finishes

Steel Products: Hot Process Black Oxide surface preparation, impregnated with naphthenic oil, centrifugally dried.

Zinc Plated Steel Products: Zinc Yellow "Trivalent" Chromate Conversion Coating to ASTM B633-85.

Aluminum Products: Bright Finish, Sulfuric Anodized MIL-A-8625 Type II, class 2

Stainless Steel Products: Bright Finish.

Black Oxide

The black oxide on our carbon steel collars and couplings is formulated as part of the total performance of the product. It enhances the holding ability of the collar/coupling, has anti-stick-slip characteristics and helps to keep the torque rating of the screw within its designed parameters. It also provides corrosion protection, although it is not intended to be used as an outside weather protective finish.

Temperature Range

Black Oxide Steel: -40° F to 350° F

Stainless Steel: -40° F to 350° F

Zinc Plated Steel: -40° F to 350° F

Aluminum: -40° F to 225° F

Anodized Aluminum: -40° F to 200° F

Plastic: -10° F to 185° F

HARDWARE TORQUE CHARTS

Torque Ratings—Clamp Screw

INCH Clamp Screw	Seating Torque (lb-in)		METRIC Clamp Screw	Seating Torque (Nm)	
	ALLOY	STAINLESS STEEL		ALLOY	STAINLESS STEEL
#2-56	6	3.8	M2	0.60	0.36
#4-40	15	8	M2.5	1.21	0.73
#6-32	28	15	M3	2.10	1.10
#8-32	49	28	M4	4.60	2.50
#10-32	76	45	M5	9.50	5.40
1/4-28	170	110	M6	16.00	9.60
5/16-24	325	190	M8	39.00	23.00
3/8-24	570	345	M10	77.00	46.00

Torque Ratings—Set Screw

INCH Set Screw	Seating Torque (lb-in)		METRIC Set Screw	Seating Torque (Nm)	
	ALLOY	STAINLESS STEEL		ALLOY	STAINLESS STEEL
#1-72	0.8	0.48	M2.5	0.57	0.44
#2-56	1.8	1.08	M3	0.92	0.73
#4-40	5.0	3.00	M4	2.20	1.76
#6-32	10.0	6.00	M5	4.00	3.20
#8-32	15.0	12.00	M6	7.20	5.76
#10-32	25.0	18.00	M8	17.00	13.60
1/4-20	87.0	70.00	M10	33.00	26.40
5/16-18	165.0	130.00			
3/8-16	290.0	230.00			
1/2-13	620.0	500.00			

HARDWARE

Inch alloy steel socket cap screws: heat treated, meet or exceed ANSI/ASME B18.3 and ASTM A574-90. Nypatch® vibration resistant feature on coupling screws. Zinc yellow chromate plated on zinc plated collars.

Metric alloy steel socket cap screws: heat treated, meet or exceed ANSI/ASME B18.3.1M and ASTM A574M-90 property class 12.9. Nypatch® vibration resistant feature on coupling screws.

Inch stainless steel socket cap screws: 18-8 (300 series) austenitic stainless steel, meet or exceed ANSI/ASME B18.3 and ASTM F837-91. Nypatch® vibration resistant feature on coupling screws.

Metric stainless steel socket cap screws: 18-8 (300 series) austenitic stainless steel, meet or exceed ANSI/ASME B18.3.1M and ASTM F837M-91. Nypatch® vibration resistant feature on coupling screws.

Inch alloy and stainless steel socket set screws: cup point, heat treated, meet or exceed ANSI/ASME B18.3, forged socket.

Metric alloy and stainless steel socket set screws: cup point, heat treated, meet or exceed ANSI/ASME B18.3.6M, forged socket.

INSTALLATION INSTRUCTIONS

Shaft Collars

1. Use collars as they are received. Do not degrease.
2. Wipe the bore clean.
3. Apply a thin coat of light oil to the shaft.
4. Place collar in desired location on shaft and tighten the collar with an unplated wrench until a slight resistance is felt.
5. On two-piece collars be sure to maintain the gap between the two halves of the collar during installation.
6. Wring collar into final position and tighten screws to the full recommended seating torque. (See charts on this page.)

Rigid Couplings

1. Align the coupling on the two shafts to be connected.
2. Tighten the Nypatch® clamp screws with an unplated wrench to half of the recommended seating torque.
3. Tighten screws to the full recommended seating torque. (See charts on this page.)
4. Be sure to maintain the gap between the two halves of the coupling on two-piece styles.

Specials: As a service to our customers, we offer our extensive machining experience and capabilities to manufacture custom parts. If you don't see what you are looking for in our standard line, please inquire about our custom fabrication service.

We are committed to have the largest variety of sizes and styles in the industry. In addition to the items listed below, we can manufacture an extensive variety of special designs. Please contact us with your custom needs.

OLDHAM COUPLING

Clamp and
set screw
styles.



BELLOWS COUPLING

Clamp and
set screw
styles.



BEAM COUPLING

Clamp and
set screw
styles.



JAW COUPLING

Clamp and
set screw
styles.



QUICK-CLAMP COLLAR

One-piece
integral
lever style.



SHAFT COLLAR

One- and
two-piece
styles.



DISC COUPLING

Clamp and
set screw
styles.



RIGID COUPLING

One- and
two-piece
styles.

