

# ASSEMBLIES

## Table of Contents

GEARBOXES - WORM WHEEL AND HELICAL GEARS TECHNICAL DATA - SPEED REDUCERS.....	C 2	SPEED REDUCER SHAFT SIZE - 1/8" .....	C 14
		SHAFT SIZE - 1/4" .....	C 15
WORM & WORM WHEEL GEARS SHAFT SIZE - 1/8", 3/16" AND 1/4".....	C 3 - C 4	PRECISION PLANETARY GEAR HEADS SHAFT SIZE - 3/8", 1/2" AND 5/8" .....	C 16
HELICAL GEARS SHAFT SIZE - 1/8", 3/16" AND 1/4".....	C 5	INTERMITTENT MOTION ASSEMBLY SHAFT SIZE - 1/4".....	C 17
BEVEL GEARBOX .....	C 6	GENEVA MECHANISM SHAFT SIZE - 1/4" .....	C 18
SHAFT SIZE - 1/8", 3/16" AND 1/4".....	C 10	CAM FOLLOWERS .....	C 19
MINIATURE MITER GEARBOX .....	C 7, C 9	ROLLER BEARING CAM FOLLOWER .....	C 20
MITER GEARBOX SHAFT SIZE - 1/8", 3/16" AND 1/4".....	C 8	ADJUSTABLE CAM ASSEMBLY .....	C 21
SERVO GEARBOX SHAFT SIZE - 1/8" .....	C 11	RATCHETS AND PAWLS .....	C 22
SHAFT SIZE - 3/16" .....	C 12		
SHAFT SIZE - 1/4" .....	C 13		

C

*For metric options, please see our metric catalog.*

# GEARBOXES - WORM WHEEL AND HELICAL GEARS

## TECHNICAL INFORMATION PRECISION SPEED REDUCERS 1/8", 3/16" and 1/4" Shafts

### Materials

<b>Housing</b>	Cast Aluminum (Anodized)
<b>Worm Wheel</b>	Bronze
<b>Worm</b>	Stainless Steel
<b>Helical Gear</b>	Aluminum
<b>Helical Pinion</b>	Stainless Steel

<b>Bearings</b>	Stainless Steel or Bronze
<b>Shafts</b>	Stainless Steel
<b>Lubrication</b>	MIL. Spec. Oil and Grease
<b>Housing Cover</b>	Aluminum
<b>All other parts</b>	Stainless Steel

### Backlash

Ball Bearing Unit 20 Minutes Max.  
Bronze Bearing Unit 30 Minutes Max.

Maximum Speed  
2000 RPM

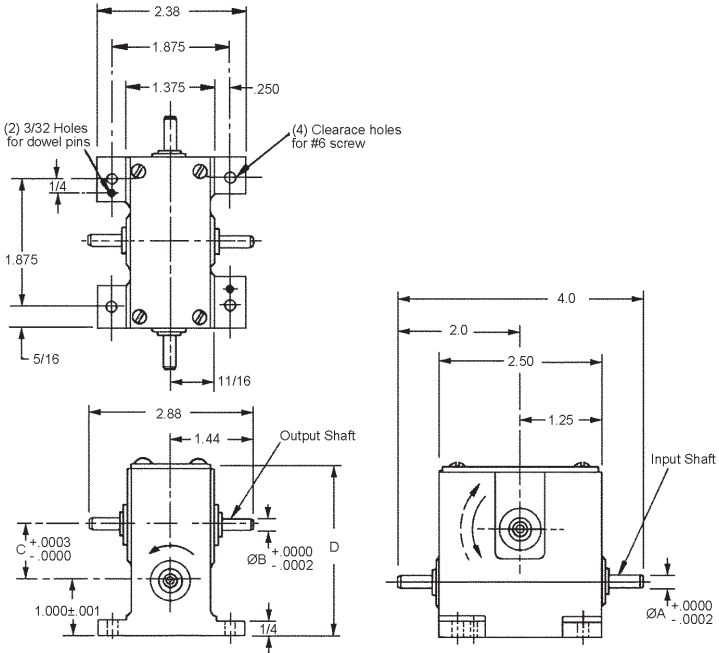

Worm and Wheel units can only be driven from input shaft and will only operate as a Speed Reducer.  
Helical Gear units can be driven from input shaft as a Speed Reducer or from output shaft as a Speed Increaser.  
Other ratios available on request.  
Anti-Backlash unit available on request.



# WORM & WORM WHEEL GEARS

SHAFT SIZE	TYPE
$\varnothing A = 1/8$ $\varnothing B = 1/8$	BALL BEARING OR BRONZE BEARING

BALL BEARINGS UNITS	BRONZE BEARINGS UNITS	PITCH	SHAFT SIZE		NOMINAL RATIO	C CENTER	D HEIGHT	MAXIMUM OUTPUT TORQUE (OZ.-IN.)
			$\varnothing A$	$\varnothing B$				
STOCK NO.	STOCK NO.							
WX64B2-1	WX64P2-1	64  WORM & WHEEL	.1247	.1247	15:1	.7191	2-11/32	112
WX64B2-2	WX64P2-2				20:1	.8753	2-5/8	160
WX64B2-3	WX64P2-3				25:1	1.0315	2-31/32	192
WX64B2-4	WX64P2-4				30:1	1.1878	3-1/4	240
WX64B2-5	WX64P2-5				30:1	.7190	2-11/32	144
WX64B2-6	WX64P2-6				40:1	.8753	2-5/8	192
WX64B2-7	WX64P2-7				50:1	1.0315	2-31/32	240
WX64B2-8	WX64P2-8				60:1	1.1878	3-1/4	288
WX64B2-9	WX64P2-9				60:1	.7190	2-11/32	144
WX64B2-10	WX64P2-10				80:1	.8753	2-5/8	192
WX64B2-11	WX64P2-11				100:1	1.0315	2-31/32	240
WX64B2-12	WX64P2-12				120:1	1.1873	3-1/4	288

SHAFT SIZE	TYPE
$\varnothing A = 3/16$ $\varnothing B = 3/16$	BALL BEARING OR BRONZE BEARING

BALL BEARINGS UNITS	BRONZE BEARINGS UNITS	PITCH	SHAFT SIZE		NOMINAL RATIO	C CENTER	D HEIGHT	MAXIMUM OUTPUT TORQUE (OZ.-IN.)
			$\varnothing A$	$\varnothing B$				
STOCK NO.	STOCK NO.							
WX64B3-1	WX64P3-1	64  WORM & WHEEL	.1872	.1872	15:1	.7190	2-11/32	112
WX64B3-2	WX64P3-2				20:1	.8753	2-5/8	160
WX64B3-3	WX64P3-3				25:1	1.0315	2-31/32	192
WX64B3-4	WX64P3-4				30:1	1.1878	3-1/4	240
WX64B3-5	WX64P3-5				30:1	.7190	2-11/32	144
WX64B3-6	WX64P3-6				40:1	.8753	2-5/8	192
WX64B3-7	WX64P3-7				50:1	1.0315	2-31/32	240
WX64B3-8	WX64P3-8				60:1	1.1878	3-1/4	288
WX64B3-9	WX64P3-9				60:1	.7190	2-11/32	144
WX64B3-10	WX64P3-10				80:1	.8753	2-5/8	192
WX64B3-11	WX64P3-11				100:1	1.0315	2-31/32	240
WX64B3-12	WX64P3-12				120:1	1.1878	3-1/4	288

SHAFT SIZE	TYPE
$\varnothing A = 1/4$ $\varnothing B = 1/4$	BALL BEARING OR BRONZE BEARING

BALL BEARINGS UNITS	BRONZE BEARINGS UNITS	PITCH	SHAFT SIZE		NOMINAL RATIO	C CENTER	D HEIGHT	MAXIMUM OUTPUT TORQUE (OZ.-IN.)
			$\varnothing A$	$\varnothing B$				
STOCK NO.	STOCK NO.							
WX64B4-1	WX64P4-1	64  WORM & WHEEL	.2497	.2497	15:1	.7190	2-11/32	112
WX64B4-2	WX64P4-2				20:1	.8753	2-5/8	160
WX64B4-3	WX64P4-3				25:1	1.0315	2-31/32	192
WX64B4-4	WX64P4-4				30:1	1.1878	3-114	240
WX64B4-5	WX64P4-5				30:1	.7190	2-11/32	144
WX64B4-6	WX64P4-6				40:1	.8753	2-5/8	192
WX64B4-7	WX64P4-7				50:1	1.0315	2-31/32	240
WX64B4-8	WX64P4-8				60:1	1.1878	3-1/4	288
WX64B4-9	WX64P4-9				60:1	.7190	2-11/32	144
WX64B4-10	WX64P4-10				80:1	.8753	2-5/8	192
WX64B4-11	WX64P4-11				100:1	1.0315	2-31/32	240
WX64B4-12	WX64P4-12				120:1	1.1878	3-1/4	288

# WORM & WORM WHEEL GEARS

SHAFT SIZE	TYPE
$\varnothing A = 1/8$ $\varnothing B = 1/8$	BALL BEARING OR BRONZE BEARING

BALL BEARINGS UNITS	BRONZE BEARINGS UNITS	PITCH	SHAFT SIZE		NOMINAL RATIO	C CENTER	D HEIGHT	MAXIMUM OUTPUT TORQUE (OZ.-IN.)
			$\varnothing A$	$\varnothing B$				
STOCK NO.	STOCK NO.	48  WORM & WHEEL	.1247	.1247	12.5:1	.6878	2-11/32	144
WX48B2-1	WX48P2-1				15:1	.7920	2-35/64	176
WX48B2-2	WX48P2-2				20:1	1.0003	2-31/32	240
WX48B2-3	WX48P2-3				22.5:1	1.1045	3-11/64	272
WX48B2-4	WX48P2-4				25:1	.6878	2-11/32	176
WX48B2-5	WX48P2-5				30:1	.7920	2-35/64	208
WX48B2-6	WX48P2-6				40:1	1.0003	2-31/32	288
WX48B2-7	WX48P2-7				45:1	1.1045	3-11/64	320
WX48B2-8	WX48P2-8				50:1	.6878	2-11/32	176
WX48B2-9	WX48P2-9				60:1	.7920	2-35/64	208
WX48B2-10	WX48P2-10				80:1	1.0003	2-31/32	288
WX48B2-11	WX48P2-11				90:1	1.1045	3-11/64	320
WX48B2-12	WX48P2-12							

SHAFT SIZE	TYPE
$\varnothing A = 3/16$ $\varnothing B = 3/16$	BALL BEARING OR BRONZE BEARING

BALL BEARINGS UNITS	BRONZE BEARINGS UNITS	PITCH	SHAFT SIZE		NOMINAL RATIO	C CENTER	D HEIGHT	MAXIMUM OUTPUT TORQUE (OZ.-IN.)
			$\varnothing A$	$\varnothing B$				
STOCK NO.	STOCK NO.	48  WORM & WHEEL	.1872	.1872	12.5:1	.6878	2-11/32	144
WX48B3-1	WX48P3-1				15:1	.7920	2-35/64	176
WX48B3-2	WX48P3-2				20:1	1.0003	2-31/32	240
WX48B3-3	WX48P3-3				22.5:1	1.1045	3-11/64	272
WX48B3-4	WX48P3-4				25:1	.6878	2-11/32	176
WX48B3-5	WX48P3-5				30:1	.7920	2-35/64	208
WX48B3-6	WX48P3-6				40:1	1.0003	2-31/32	288
WX48B3-7	WX48P3-7				45:1	1.1045	3-11/64	320
WX48B3-8	WX48P3-8				50:1	.6878	2-11/32	176
WX48B3-9	WX48P3-9				60:1	.7920	2-35/64	208
WX48B3-10	WX48P3-10				80:1	1.0003	2-31/32	288
WX48B3-11	WX48P3-11				90:1	1.1045	3-11/64	320
WX48B3-12	WX48P3-12							

SHAFT SIZE	TYPE
$\varnothing A = 3/16$ $\varnothing B = 1/4$	BALL BEARING OR BRONZE BEARING

BALL BEARINGS UNITS	BRONZE BEARINGS UNITS	PITCH	SHAFT SIZE		NOMINAL RATIO	C CENTER	D HEIGHT	MAXIMUM OUTPUT TORQUE (OZ.-IN.)
			$\varnothing A$	$\varnothing B$				
STOCK NO.	STOCK NO.	48  WORM & WHEEL	.1872	.2497	12.5:1	.6878	2-11/32	144
WX48B43-1	WX48P43-1				15:1	.7920	2-35/64	176
WX48B43-2	WX48P43-2				20:1	1.0003	2-31/32	240
WX48B43-3	WX48P43-3				22.5:1	1.1045	3-11/64	272
WX48B43-4	WX48P43-4				25:1	.6878	2-11/32	176
WX48B43-5	WX48P43-5				30:1	.7920	2-35/64	208
WX48B43-6	WX48P43-6				40:1	1.0003	2-31/32	288
WX48B43-7	WX48P43-7				45:1	1.1040	3-11/64	320
WX48B43-8	WX48P43-8				50:1	.6878	2-11/32	176
WX48B43-9	WX48P43-9				60:1	.7920	2-35/64	208
WX48B43-10	WX48P43-10				80:1	1.0003	2-31/32	288
WX48B43-11	WX48P43-11				90:1	1.1045	3-11/64	320
WX48B43-12	WX48P43-12							

# HELICAL GEARS

SHAFT SIZE	TYPE
$\varnothing A = 1/8$ $\varnothing B = 1/8$	BALL BEARING OR BRONZE BEARING

BALL BEARINGS UNITS	BRONZE BEARINGS UNITS	PITCH	SHAFT SIZE		NOMINAL RATIO	C CENTER	D HEIGHT	MAXIMUM OUTPUT TORQUE (OZ.-IN.)
			$\varnothing A$	$\varnothing B$				
STOCK NO.	STOCK NO.	64 HELICAL	.1247	.1247	1:1	.4422	1-25/32	49
HX64B2-1	HX64P2-1				2:1	.6632	2-15/64	
HX64B2-2	HX64P2-2				3:1	.8841	2-43/64	
HX64B2-3	HX64P2-3				4:1	1.1051	3-7/64	
HX64B2-4	HX64P2-4							

SHAFT SIZE	TYPE
$\varnothing A = 3/16$ $\varnothing B = 3/16$	BALL BEARING OR BRONZE BEARING

BALL BEARINGS UNITS	BRONZE BEARINGS UNITS	PITCH	SHAFT SIZE		NOMINAL RATIO	C CENTER	D HEIGHT	MAXIMUM OUTPUT TORQUE (OZ.-IN.)
			$\varnothing A$	$\varnothing B$				
STOCK NO.	STOCK NO.	64 HELICAL	.1872	.1872	1:1	.4422	1-25/32	73
HX64B3-1	HX64P3-1				2:1	.6632	2-15/16	
HX64B3-2	HX64P3-2				3:1	.8841	2-43/64	
HX64B3-3	HX64P3-3				4:1	1.1051	3-7/64	
HX64B3-4	HX64P3-4							

SHAFT SIZE	TYPE
$\varnothing A = 3/16$ $\varnothing B = 3/16$	BALL BEARING OR BRONZE BEARING

BALL BEARINGS UNITS	BRONZE BEARINGS UNITS	PITCH	SHAFT SIZE		NOMINAL RATIO	C CENTER	D HEIGHT	MAXIMUM OUTPUT TORQUE (OZ.-IN.)
			$\varnothing A$	$\varnothing B$				
STOCK NO.	STOCK NO.	48 HELICAL	.1872	.1872	1:1	.5895	2-1/64	73
HX48B3-1	HX48P3-1				2:1	.8841	2-19/32	
HX48B3-2	HX48P3-2				3:1	1.1787	3-3/16	
HX48B3-3	HX48P3-3							

SHAFT SIZE	TYPE
$\varnothing A = 3/16$ $\varnothing B = 1/4$	BALL BEARING OR BRONZE BEARING

BALL BEARINGS UNITS	BRONZE BEARINGS UNITS	PITCH	SHAFT SIZE		NOMINAL RATIO	C CENTER	D HEIGHT	MAXIMUM OUTPUT TORQUE (OZ.-IN.)
			$\varnothing A$	$\varnothing B$				
STOCK NO.	STOCK NO.	48 HELICAL	.2497	.2497	1:1	.5895	2-1/64	130
HX48B4-1	HX48P4-1				2:1	.8841	2-19/32	
HX48B4-2	HX48P4-2				3:1	1.1787	3-3/16	
HX48B4-3	HX48P4-3							

# BEVEL GEARBOX

SHAFT SIZE	RATIOS	TYPE
1/4" OR 5 MM	1:1 and 1:2	BRONZE BEARING

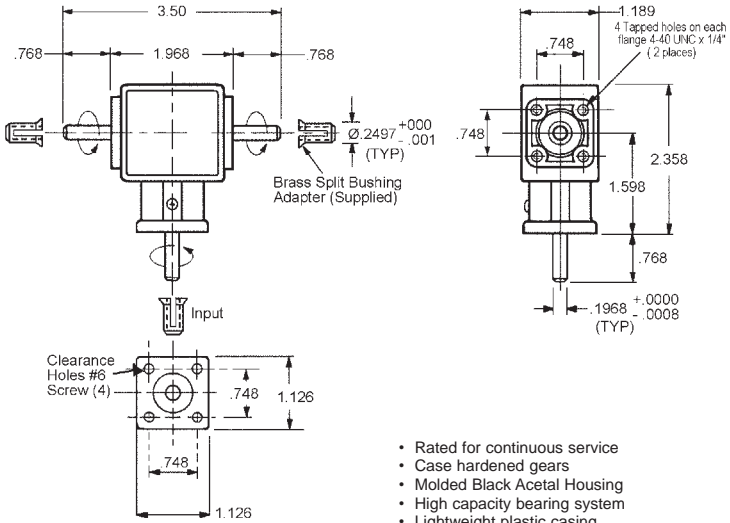

- Rated for continuous service
- Case hardened gears
- Molded Black Acetal Housing
- High capacity bearing system
- Lightweight plastic casing
- Surface hardened, corrosion resistant shafts
- Lubricated for life-enhanced by grease control ribs

The gearbox is a right angle drive available in bevel or miter gear versions. The gearbox has a continuous rating and is suitable for instrument and light duty drives. It is both economical and reliable.

STOCK NO.	RATIO	RPM MAX.	OPERATING TORQUE	BACKLASH MAX.
MX-16	1:1	1500	48 OZ. IN.	2°
MX-17	1:2	1500	96 OZ. IN.	2°

# MINIATURE MITER GEARBOX

SHAFT SIZE	RATIOS	TYPE
1/4" OR 4 MM	1:1	BRONZE BEARING

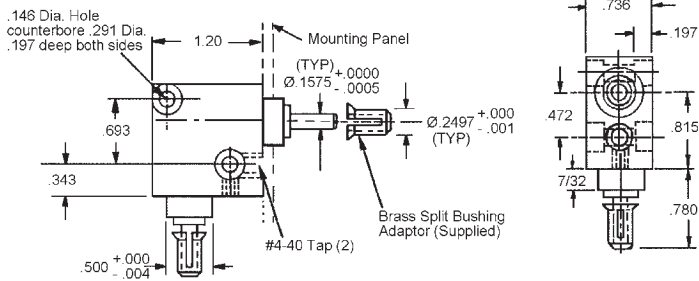

STOCK NO.	GEAR MATERIAL	OPERATING TORQUE
MX-14	HARDENED STEEL	98 OZ. IN.

- Molded Black Acetal Housing
- Ground and hardened steel shaft
- Sintered bronze bearing system
- Gearbox and bearings lubricated for life
- 000 RPM Maximum

# MITER GEARBOX

SHAFT SIZE	RATIOS	TYPE
1/8"	1:1	BALL BEARING OR BRONZE BEARING

**MATERIAL:**  
**Housing**  
**Shafts and Hardware**  
**Bearings**  
**Gears**  
**Lubrication**

Aluminum  
 Stainless Steel  
 Stainless Steel or Bronze  
 Stainless Steel and Aluminum  
 MIL. Spec. Oil and Grease

Consult Berg's Engineering  
 Department for higher torque units.

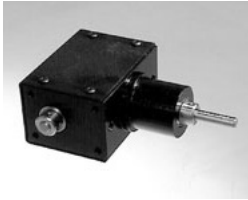
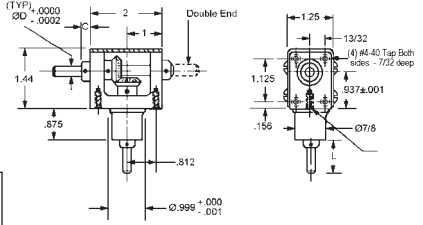

ABEC 7 BALL BEARING	OIL-LESS BRONZE BEARING UNIT	ØD	C	L	SHAFT END STYLE	R.P.M. (MAX.)	TORQUE (MAX.)
STOCK NO.	STOCK NO.						
MX-1	MX-1B	.1247	.187	.71	SINGLE	1000	200
MX-1-D	MX-1B-D				DOUBLE		OZ.IN.

SHAFT SIZE	RATIOS	TYPE
3/16"	1:1	BALL BEARING OR BRONZE BEARING

**MATERIAL:**  
**Housing**  
**Shafts and Hardware**  
**Bearings**  
**Gears**  
**Lubrication**

Aluminum  
 Stainless Steel  
 Stainless Steel or Bronze  
 Stainless Steel and Aluminum  
 MIL. Spec. Oil and Grease

Consult Berg's Engineering  
 Department for higher torque units.

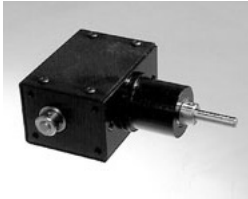
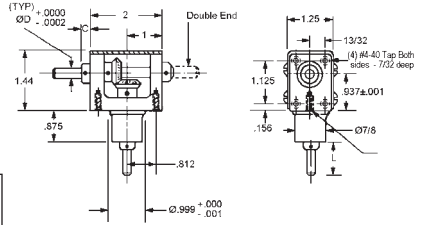

ABEC 7 BALL BEARING	OIL-LESS BRONZE BEARING UNIT	ØD	C	L	SHAFT END STYLE	R.P.M. (MAX.)	TORQUE (MAX.)
STOCK NO.	STOCK NO.						
MX-2	MX-2B	.1872	.220	.87	SINGLE	2000	300
MX-2-D	MX-2B-D				DOUBLE		OZ.IN.

SHAFT SIZE	RATIOS	TYPE
1/4"	1:1	BALL BEARING OR BRONZE BEARING

**MATERIAL:**  
**Housing**  
**Shafts and Hardware**  
**Bearings**  
**Gears**  
**Lubrication**

Aluminum  
 Stainless Steel  
 Stainless Steel or Bronze  
 Stainless Steel and Aluminum  
 MIL. Spec. Oil and Grease

Consult Berg's Engineering  
 Department for higher torque units.

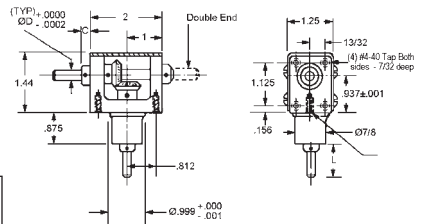

ABEC 7 BALL BEARING	OIL-LESS BRONZE BEARING UNIT	ØD	C	L	SHAFT END STYLE	R.P.M. (MAX.)	TORQUE (MAX.)
STOCK NO.	STOCK NO.						
MX-3	MX-3B	.2497	.250	1.03	SINGLE	2500	500
MX-3-D	MX-3B-D				DOUBLE		OZ.IN.



# MINIATURE MITER GEARBOX

SHAFT SIZE	RATIOS	TYPE
1/8"	1:1	BALL BEARING OR BRONZE BEARING

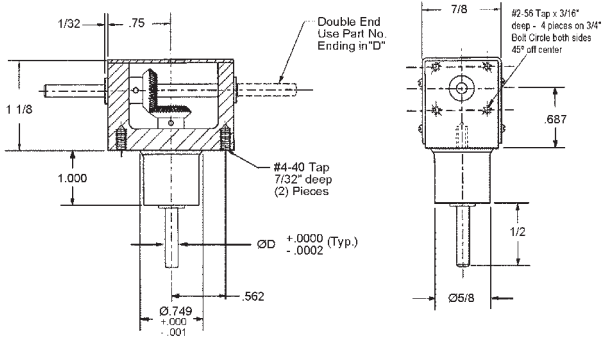

**MATERIAL:**

<b>Housing</b>	Aluminum
<b>Shafts and Hardware</b>	Stainless Steel
<b>Bearings</b>	Stainless Steel or Bronze
<b>Gears</b>	Stainless Steel and Aluminum
<b>Lubrication</b>	MIL. Spec. Oil and Grease

STOCK NO.	STOCK NO.	ØD	SHAFT END STYLE	R.P.M. (MAX.)	TORQUE (MAX.)
ABEC 7 BALL BEARING	OIL-LESS BRONZE BEARING UNIT				
MX-4	MX-4B	.1247	SINGLE	1000	100
MX-4-D	MX-4B-D	.1247	DOUBLE		OZ. IN.



Consult Berg's Engineering Department for higher torque units.  
Anti-Backlash units available on request.

# BEVEL GEARBOX

SHAFT SIZE	RATIOS	TYPE
1/8"	FROM 1:1 TO 1:3	BALL BEARING OR BRONZE BEARING

ABEC 7 BALL BEARING	OIL-LESS BRONZE BEARING UNIT	NOMINAL RATIO	ØD	B	C	E	F	G	H	A	RPM (MAX.)	STATIC TORQUE (MAX.)
STOCK NO.	STOCK NO.											
MX-5 MX-6 MX-7	MX-5B MX-6B MX-7B	1:1 1:2 1:3	.1247	2-3/4	1-7/8	1-5/8	1-7/8	13/16	1-7/16 1-11/16 1-15/16	1.000	1000	60 OZ. IN.

- Maximum backlash 10 minutes
- Units can be driven in either direction from any shaft

MATERIAL: **Housing** Aluminum  
**Shafts and Hardware** Stainless Steel  
**Bearings** Stainless Steel or Bronze  
**Gears** Stainless Steel and Aluminum  
**Lubrication** MIL. Spec. Oil and Grease

SHAFT SIZE	RATIOS	TYPE
3/16"	FROM 1:1 TO 1:3	BALL BEARING OR BRONZE BEARING

ABEC 7 BALL BEARING	OIL-LESS BRONZE BEARING UNIT	NOMINAL RATIO	ØD	B	C	E	F	G	H	A	RPM (MAX.)	STATIC TORQUE (MAX.)
STOCK NO.	STOCK NO.											
MX-8 MX-9 MX-10	MX-8B MX-9B MX-10B	1:1 1:2 1:3	.1872	2-3/4	1-7/8	1-5/8	1-7/8	13/16	1-7/16 1-11/16 1-15/16	1.000	2000	80 OZ. IN.

- Maximum backlash 10 minutes
- Units can be driven in either direction from any shaft

MATERIAL: **Housing** Aluminum  
**Shafts and Hardware** Stainless Steel  
**Bearings** Stainless Steel or Bronze  
**Gears** Stainless Steel and Aluminum  
**Lubrication** MIL. Spec. Oil and Grease

SHAFT SIZE	RATIOS	TYPE
1/4"	FROM 1:1 TO 1:3	BALL BEARING OR BRONZE BEARING

ABEC 7 BALL BEARING	OIL-LESS BRONZE BEARING UNIT	NOMINAL RATIO	ØD	B	C	E	F	G	H	A	RPM (MAX.)	STATIC TORQUE (MAX.)
STOCK NO.	STOCK NO.											
MX-11 MX-12 MX-13	MX-11B MX-12B MX-13B	1:1 1:2 1:3	.2498	3-1/2	2-5/8	2	2-1/4	15/16	2 2-5/16 2-9/16	1.500	2500	100 OZ. IN.

- Maximum backlash 10 minutes
- Units can be driven in either direction from any shaft

MATERIAL: **Housing** Aluminum  
**Shafts and Hardware** Stainless Steel  
**Bearings** Stainless Steel or Bronze  
**Gears** Stainless Steel and Aluminum  
**Lubrication** MIL. Spec. Oil and Grease

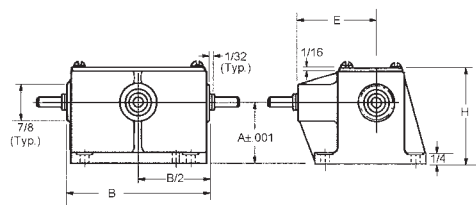
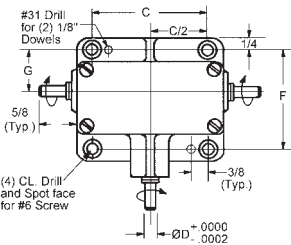

# SERVO GEARBOX - PRECISION SPEED REDUCER

SHAFT SIZE	RATIOS	TYPE
1/8"	2:1 TO 625:1	BALL BEARING OR BRONZE BEARING



Special units available on request.

Anti-Backlash gear - Output End

Slip Clutch included - Input End

Contact Berg's Engineering Department for recommendations for use as a Speed Increaser.

• See instructions below to order alternate shaft locations.

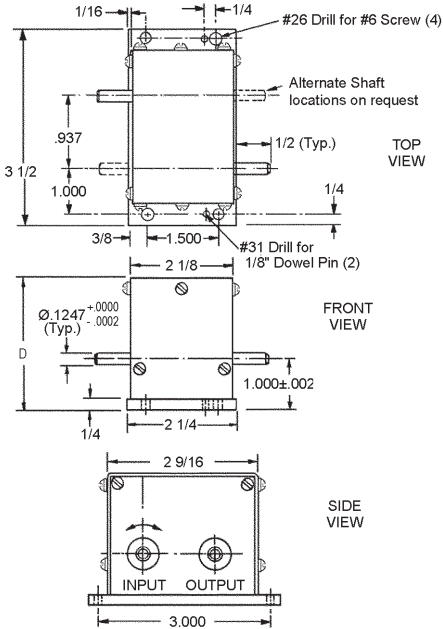

ABEC 7 BALL BEARINGS UNITS	BRONZE BEARINGS UNITS	STOCK NO.	STOCK NO.	NOMINAL RATIO	D HEIGHT	DIRECTION ROTATION
SX-B2-1	SX-P2-1			2:1	2-1/2	SAME
SX-B2-2	SX-P2-2			3:1		
SX-B2-3	SX-P2-3			4:1		
SX-B2-4	SX-P2-4			5:1		
SX-B2-5	SX-P2-5			6:1		
SX-B2-6	SX-P2-6			7:1		
SX-B2-7	SX-P2-7			8:1		
SX-B2-8	SX-P2-8			9:1		
SX-B2-9	SX-P2-9			10:1		
SX-B2-10	SX-P2-10			12:1		
SX-B2-11	SX-P2-11			15:1		
SX-B2-12	SX-P2-12			16:1		
SX-B2-13	SX-P2-13			20:1		
SX-B2-14	SX-P2-14			25:1		
SX-B2-15	SX-P2-15			30:1	2-5/8	OPPOSITE
SX-B2-16	SX-P2-16			32:1		
SX-B2-17	SX-P2-17			36:1		
SX-B2-18	SX-P2-18			40:1		
SX-B2-19	SX-P2-19			45:1		
SX-B2-20	SX-P2-20			48:1		
SX-B2-21	SX-P2-21			50:1		
SX-B2-22	SX-P2-22			60:1		
SX-B2-23	SX-P2-23			64:1		
SX-B2-24	SX-P2-24			75:1		
SX-B2-25	SX-P2-25			80:1		
SX-B2-26	SX-P2-26			100:1		
SX-B2-27	SX-P2-27			125:1		
SX-B2-28	SX-P2-28			72:1	3-5/16	SAME
SX-B2-29	SX-P2-29			90:1		
SX-B2-30	SX-P2-30			96:1		
SX-B2-31	SX-P2-31			128:1		
SX-B2-32	SX-P2-32			150:1		
SX-B2-33	SX-P2-33			180:1		
SX-B2-34	SX-P2-34			200:1		
SX-B2-35	SX-P2-35			250:1		
SX-B2-36	SX-P2-36			256:1		
SX-B2-37	SX-P2-37			300:1		
SX-B2-38	SX-P2-38			375:1		
SX-B2-39	SX-P2-39			400:1		
SX-B2-40	SX-P2-40			500:1		
SX-B2-41	SX-P2-41			625:1		

## Alternate Shaft Locations

Add **Style Letter** to complete stock number, if different from that shown.

### Style:

- O = Opposite of as shown
- R = In and Out on R.H. side only
- L = In and Out on L.H. side only
- A = In and Out on all sides

Send drawing if other than listed above.

## Backlash

At Output Shaft

- Ball Bearing - 15 Minutes Max.
- Bronze Bearing - 30 Minutes Max.

## Materials

### Housing and Cover

Aluminum Anodized

### Gears

Stainless Steel and Aluminum

### Shafts and Hardware

Stainless Steel

### Bearings

Stainless Steel or Bronze

### Lubrication

MIL. Spec. Oil and Grease

## Maximum Speed

5000 RPM

## Maximum Output Torque

300 Oz. In.

# SERVO GEARBOX

SHAFT SIZE	RATIOS	TYPE
3/16"	2:1 TO 625:1	BALL BEARING OR BRONZE BEARING



Special units available on request.

Anti-Backlash gear - Output End

Slip Clutch included - Input End

Contact Berg's Engineering Department for recommendations for use as a Speed Increaser.

- See instructions below to order alternate shaft locations.

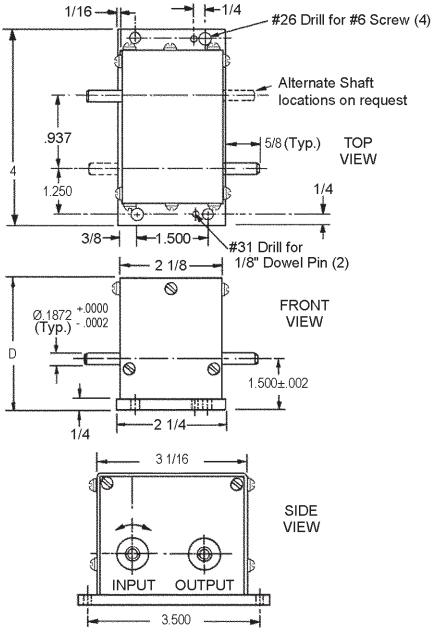

ABEC 7 BALL BEARINGS UNITS	BRONZE BEARINGS UNITS	STOCK NO.	STOCK NO.	NOMINAL RATIO	D HEIGHT	DIRECTION ROTATION
SX-B3-1	SX-P3-1			2:1	3-3/8	SAME
SX-B3-2	SX-P3-2			3:1		
SX-B3-3	SX-P3-3			4:1		
SX-B3-4	SX-P3-4			5:1		
SX-B3-5	SX-P3-5			6:1		
SX-B3-6	SX-P3-6			7:1		
SX-B3-7	SX-P3-7			8:1		
SX-B3-8	SX-P3-8			9:1		
SX-B3-9	SX-P3-9			10:1		
SX-B3-10	SX-P3-10			12:1		
SX-B3-11	SX-P3-11			15:1		
SX-B3-12	SX-P3-12			16:1		
SX-B3-13	SX-P3-13			20:1		
SX-B3-14	SX-P3-14			25:1		
SX-B3-15	SX-P3-15			30:1	3-3/8	OPPOSITE
SX-B3-16	SX-P3-16			32:1		
SX-B3-17	SX-P3-17			36:1		
SX-B3-18	SX-P3-18			40:1		
SX-B3-19	SX-P3-19			45:1		
SX-B3-20	SX-P3-20			48:1		
SX-B3-21	SX-P3-21			50:1		
SX-B3-22	SX-P3-22			60:1		
SX-B3-23	SX-P3-23			64:1		
SX-B3-24	SX-P3-24			75:1		
SX-B3-25	SX-P3-25			80:1		
SX-B3-26	SX-P3-26			100:1		
SX-B3-27	SX-P3-27			125:1		
SX-B3-28	SX-P3-28			72:1	4-9/32	SAME
SX-B3-29	SX-P3-29			90:1		
SX-B3-30	SX-P3-30			96:1		
SX-B3-31	SX-P3-31			128:1		
SX-B3-32	SX-P3-32			150:1		
SX-B3-33	SX-P3-33			180:1		
SX-B3-34	SX-P3-34			200:1		
SX-B3-35	SX-P3-35			250:1		
SX-B3-36	SX-P3-36			256:1		
SX-B3-37	SX-P3-37			300:1		
SX-B3-38	SX-P3-38			375:1		
SX-B3-39	SX-P3-39			400:1		
SX-B3-40	SX-P3-40			500:1		
SX-B3-41	SX-P3-41			625:1		

Alternate Shaft Locations  
 Add **Style Letter** to complete stock number, if different from that shown.

**Style:**

- O = Opposite of as shown
- R = In and Out on R.H. side only
- L = In and Out on L.H. side only
- A = In and Out on all sides

Send drawing if other than listed above.

**Backlash**

At Output Shaft

- Ball Bearing - 15 Minutes Max.
- Bronze Bearing - 30 Minutes Max.

**Materials**

**Housing and Cover**

Aluminum Anodized

**Gears**

Stainless Steel and Aluminum

**Shafts and Hardware**

Stainless Steel

**Bearings**

Stainless Steel or Bronze

**Lubrication**

MIL. Spec. Oil and Grease

**Maximum Speed**

5000 RPM

**Maximum Output Torque**

400 Oz. In.

# SERVO GEARBOXES

SHAFT SIZE	RATIOS	TYPE
1/4"	2:1 TO 625:1	BALL BEARING OR BRONZE BEARING



Special units available on request.

Anti-Backlash gear - Output End

Slip Clutch included - Input End

Contact Berg's Engineering Department for recommendations for use as a Speed Increaser.

• See instructions below to order alternate shaft locations.

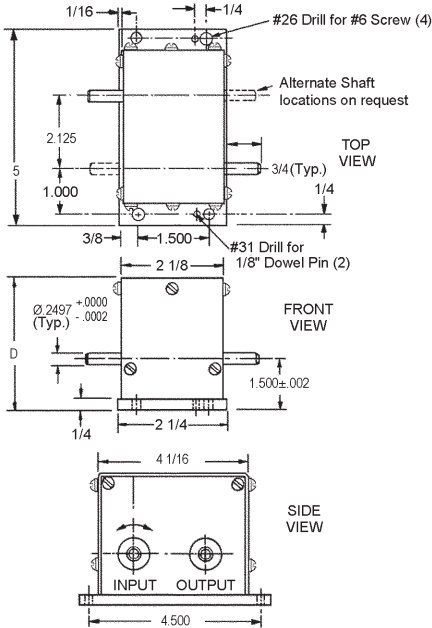

ABEC 7 BALL BEARINGS UNITS	BRONZE BEARINGS UNITS	STOCK NO.	STOCK NO.	NOMINAL RATIO	D HEIGHT	DIRECTION ROTATION
SX-B4-1	SX-P4-1			2:1	3-9/32	SAME
SX-B4-2	SX-P4-2			3:1		
SX-B4-3	SX-P4-3			4:1		
SX-B4-4	SX-P4-4			5:1		
SX-B4-5	SX-P4-5			6:1		
SX-B4-6	SX-P4-6			7:1		
SX-B4-7	SX-P4-7			8:1		
SX-B4-8	SX-P4-8			9:1		
SX-B4-9	SX-P4-9			10:1		
SX-B4-10	SX-P4-10			12:1		
SX-B4-11	SX-P4-11			15:1		
SX-B4-12	SX-P4-12			16:1		
SX-B4-13	SX-P4-13			20:1		
SX-B4-14	SX-P4-14			25:1		
SX-B4-15	SX-P4-15			30:1	3-13/16	OPPOSITE
SX-B4-16	SX-P4-16			32:1		
SX-B4-17	SX-P4-17			36:1		
SX-B4-18	SX-P4-18			40:1		
SX-B4-19	SX-P4-19			45:1		
SX-B4-20	SX-P4-20			48:1		
SX-B4-21	SX-P4-21			50:1		
SX-B4-22	SX-P4-22			60:1		
SX-B4-23	SX-P4-23			64:1		
SX-B4-24	SX-P4-24			75:1		
SX-B4-25	SX-P4-25			80:1		
SX-B4-26	SX-P4-26			100:1		
SX-B4-27	SX-P4-27			125:1		
SX-B4-28	SX-P4-28			72:1	4-13/16	SAME
SX-B4-29	SX-P4-29			90:1		
SX-B4-30	SX-P4-30			96:1		
SX-B4-31	SX-P4-31			128:1		
SX-B4-32	SX-P4-32			150:1		
SX-B4-33	SX-P4-33			180:1		
SX-B4-34	SX-P4-34			200:1		
SX-B4-35	SX-P4-35			250:1		
SX-B4-36	SX-P4-36			256:1		
SX-B4-37	SX-P4-37			300:1		
SX-B4-38	SX-P4-38			375:1		
SX-B4-39	SX-P4-39			400:1		
SX-B4-40	SX-P4-40			500:1		
SX-B4-41	SX-P4-41			625:1		

## Alternate Shaft Locations

Add **Style Letter** to complete stock number, if different from that shown.

### Style:

- O = Opposite of as shown
- R = In and Out on R.H. side only
- L = In and Out on L.H. side only
- A = In and Out on all sides

Send drawing if other than listed above.

## Backlash

At Output Shaft

- Ball Bearing - 15 Minutes Max.
- Bronze Bearing - 30 Minutes Max.

## Materials

### Housing and Cover

Aluminum Anodized

### Gears

Stainless Steel and Aluminum

### Shafts and Hardware

Stainless Steel

### Bearings

Stainless Steel or Bronze

### Lubrication

MIL. Spec. Oil and Grease

Maximum Speed

5000 RPM

Maximum Output Torque

600 Oz. In.

# SPEED REDUCER

SHAFT	SIZE	DIAMETER	BEARINGS	RATIOS
1/8"	11	1-1/16"	ABEC -5	9:1 to 3600:1.

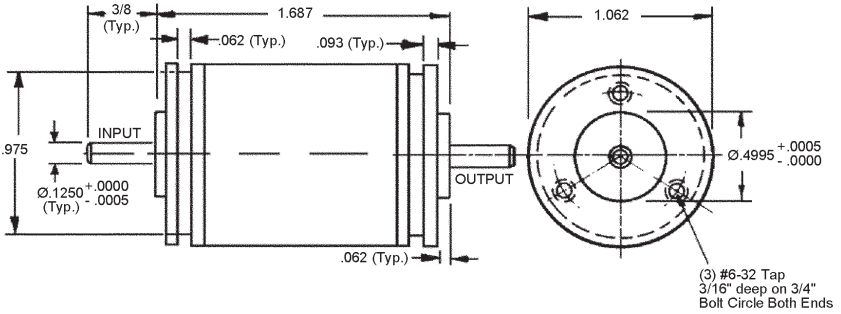

- Starting Torque (Max.) .005 Oz. In.
- Rated Output Torque 65 Oz. In.
- Maximum Backlash  $0^{\circ} 30'$
- Moment of Inertia at Input Shaft .015 gm-cm<sup>2</sup>
- Approximate Weight 3 Oz.
- Ball Bearings On All Cluster Shafts



STOCK NO.	NOMINAL RATIO	NO. OF SHAFT ROTATION	GEAR CLUSTERS
RX11-1	9:1	SAME	1
RX11-2	10:1		
RX11-3	12:1		
RX11-4	15:1		
RX11-5	20:1		
RX11-6	25:1		
RX11-7	30:1	OPPOSITE	2
RX11-8	40:1	SAME	3
RX11-9	50:1		
RX11-10	60:1	OPPOSITE	2
RX11-11	80:1	SAME	3
RX11-12	90:1		
RX11-13	100:1		
RX11-14	180:1		
RX11-15	200:1	OPPOSITE	4
RX11-16	300:1		
RX11-17	360:1		
RX11-18	400:1	SAME	5
RX11-19	500:1		
RX11-20	600:1		
RX11-21	800:1		
RX11-22	1000:1	OPPOSITE	6
RX11-23	2000:1		
RX11-24	3000:1	SAME	5
RX11-25	3600:1		

# SPEED REDUCER

SHAFT	SIZE	DIAMETER	BEARINGS	RATIOS
1/4"	18	1-3/4"	ABEC -5	4.96:1 to 3000:1

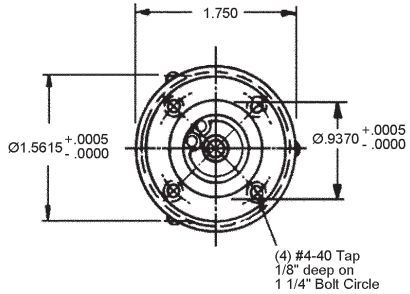
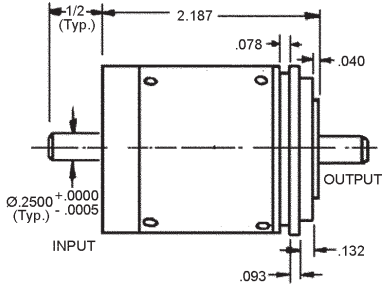

- Starting Torque (Max.) .03 Oz. In.
- Rated Output Torque 125 Oz. In.
- Maximum Backlash 0° 30'
- Moment of Inertia at Input Shaft .035 gm-cm<sup>2</sup>
- Approximate Weight 8 Oz.
- Ball Bearings On All Cluster Shafts



STOCK NO.	NOMINAL RATIO	NO. OF SHAFT ROTATION	GEAR CLUSTERS
RX18-1 RX18-2	4.96:1 6:1	SAME	1
RX18-3 RX18-4	9.93:1 15.27:1	OPPOSITE	2
RX18-5	20:1	SAME	1
RX18-6 RX18-7	30:1 40:1	OPPOSITE	2
RX18-8 RX18-9 RX18-10	50.9:1 80:1 100:1		
RX18-11 RX18-12 RX18-13	124.8:1 150:1 200:1		
RX18-14 RX18-15 RX18-16 RX18-17	248.16:1 300.3:1 400:1 500:1	SAME	3
RX18-18 RX18-19 RX18-20	600:1 1000:1 1600:1	OPPOSITE	4
RX18-21	1800:1	OPPOSITE	6
RX18-22	2000:1	OPPOSITE	4
RX18-23	2300:1	SAME	5
RX18-24	2500:1	OPPOSITE	4
RX18-25	3000:1	SAME	5

# PRECISION PLANETARY GEAR HEADS

SHAFT SIZES			RATIOS		
3/8	1/2	5/8	3:1 TO 100:1		

## NEMA PLANETARY GEARHEADS

STOCK NO.	RATIO	A	B	C	D	ØE	F	G	H	I	J	K	L	M	N	O	P
GHNE23-3	3:1	2.27	.195	2.625	1.500	.375	1.00	.062	.19	.00	.17	.125	2.30	-	.75	.15	-
GHNE23-5	5:1	2.27	.195	2.625	1.500	.375	1.00	.062	.19	.00	.17	.125	2.30	-	.75	.15	-
GHNE23-8	8:1	2.27	.195	2.625	1.500	.375	1.00	.062	.19	.00	.17	.125	2.30	-	.75	.15	-
GHNE23-10	10:1	2.27	.195	2.625	1.500	.375	1.00	.062	.19	.00	.17	.125	2.30	-	.75	.15	-
GHNE23-15	15:1	2.27	.195	2.625	1.500	.375	1.00	.062	.19	.00	.17	.125	2.30	-	.75	.15	-
GHNE23-20	20:1	2.27	.195	2.625	1.500	.375	1.00	.062	.19	.00	.17	.125	2.30	-	.75	.15	-
GHNE23-30	30:1	2.27	.195	2.625	1.500	.375	1.00	.062	.19	.00	.17	.125	2.30	-	.75	.15	-
GHNE23-50	50:1	2.27	.195	2.625	1.500	.375	1.00	.062	.19	.00	.17	.125	2.30	-	.75	.15	-
GHNE23-100	100:1	2.27	.195	2.625	1.500	.375	1.00	.062	.19	.00	.17	.125	2.30	-	.75	.15	-
GHNE34-3	3:1	3.25	.218	3.875	2.875	.500	1.25	.062	.38	.38	2.876	.200	3.00	-	1.06	.07	.125
GHNE34-5	5:1	3.25	.218	3.875	2.875	.500	1.25	.062	.38	.38	2.876	.200	3.00	-	1.06	.07	.125
GHNE34-8	8:1	3.25	.218	3.875	2.875	.500	1.25	.062	.38	.38	2.876	.200	3.00	-	1.06	.07	.125
GHNE34-10	10:1	3.25	.218	3.875	2.875	.500	1.25	.062	.38	.38	2.876	.200	3.00	-	1.06	.07	.125
GHNE34-15	15:1	3.25	.218	3.875	2.875	.500	1.25	.062	.38	.38	2.876	.200	3.00	-	1.06	.07	.125
GHNE34-20	20:1	3.25	.218	3.875	2.875	.500	1.25	.062	.38	.38	2.876	.200	3.00	-	1.06	.07	.125
GHNE34-30	30:1	3.25	.218	3.875	2.875	.500	1.25	.062	.38	.38	2.876	.200	3.00	-	1.06	.07	.125
GHNE34-50	50:1	3.25	.218	3.875	2.875	.500	1.25	.062	.38	.38	2.876	.200	3.00	-	1.06	.07	.125
GHNE34-100	100:1	3.25	.218	3.875	2.875	.500	1.25	.062	.38	.38	2.876	.200	3.00	-	1.06	.07	.125
GHNE42-3	3:1	4.25	.281	4.950	2.187	.625	1.50	.093	0.50	5.63	2.188	.188	3.75	-	1.13	.11	.188
GHNE42-5	5:1	4.25	.281	4.950	2.187	.625	1.50	.093	0.50	5.63	2.188	.188	3.75	-	1.13	.11	.188
GHNE42-8	8:1	4.25	.281	4.950	2.187	.625	1.50	.093	0.50	5.63	2.188	.188	3.75	-	1.13	.11	.188
GHNE42-10	10:1	4.25	.281	4.950	2.187	.625	1.50	.093	0.50	5.63	2.188	.188	3.75	-	1.13	.11	.188
GHNE42-15	15:1	4.25	.281	4.950	2.187	.625	1.50	.093	0.50	5.63	2.188	.188	3.75	-	1.13	.11	.188
GHNE42-20	20:1	4.25	.281	4.950	2.187	.625	1.50	.093	0.50	5.63	2.188	.188	3.75	-	1.13	.11	.188
GHNE42-30	30:1	4.25	.281	4.950	2.187	.625	1.50	.093	0.50	5.63	2.188	.188	3.75	-	1.13	.11	.188
GHNE42-50	50:1	4.25	.281	4.950	2.187	.625	1.50	.093	0.50	5.63	2.188	.188	3.75	-	1.13	.11	.188
GHNE42-100	100:1	4.25	.281	4.950	2.187	.625	1.50	.093	0.50	5.63	2.188	.188	3.75	-	1.13	.11	.188

Obsolete  
Contact factory for more information

## PLANETARY GEAR HEADS PERFORMANCE SPECIFICATIONS

STOCK NO	RATED OUTPUT TOR. In-Lbs	PEAK OUTPUT TOR. In-Lbs	RATED INPUT SP. RPM	BACK LASH MIN.	*LOW BACK LASH MIN.	AVE. EFF. %	MOM. OF IN. Oz-in-sec <sup>2</sup>	MAX. WEIGHT lbs	RAD LOAD <sup>(1)</sup> lbs	AXIAL LOAD lbs
GHNE23	50	100	4000	20	10	92	7x10-5	1.2	20	40
GHNE34	250	500	4000	20	10	92	5x10-4	3.0	50	100
GHNE42	500	1000	4000	20	10	92	4x10-3	6.0	250	250

<sup>(1)</sup> Radial loads are at 0.5 inches from the face of the gear head.

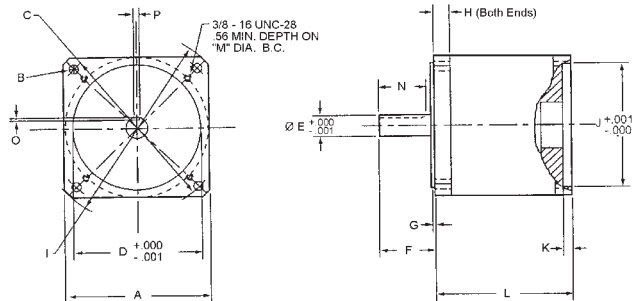

### Materials:

- Housing** - Anodized Aluminum
- Gears** - Stainless Steel Q12 / DIN 7 Quality Class
- Shafts** - Stainless Steel
- Bearings** - Stainless Steel or Bronze
- Lubrication** - Sny. Grease

- Low Backlash available on request.



# INTERMITTENT MOTION ASSEMBLY

SHAFT	PITCH GEARS	TYPE
1/4"	48	BALL BEARING

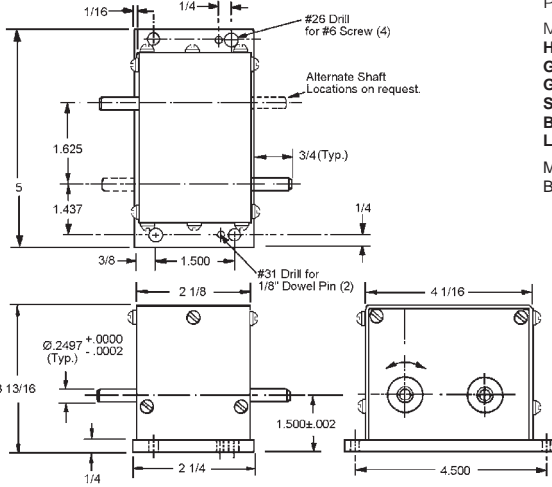

Precision Geneva Mechanism

Materials:

**Housing and Cover** - Anodized Aluminum

**Geneva** - Stainless Steel

**Gears** - Stainless Steel and Aluminum

**Shafts and Hardware** - Stainless Steel

**Bearings** - Stainless Steel - ABEC 7

**Lubrication** - MIL Spec. Oil and Grease

Max. Input Speed - 300 RPM

Backlash at Output Shaft - 30 Minutes Max.

PRECISION BALL BEARING UNIT	ROTATION OF OUTPUT SHAFT PER EACH 360° REV. OF INPUT
STOCK NUMBER	
GX-1	90 DEGREES
GX-2	60 DEGREES
GX-3	45 DEGREES
GX-4	30 DEGREES
GX-5	22.5 DEGREES
GX-6	10 DEGREES

PRECISION BALL BEARING UNIT	ROTATION OF OUTPUT SHAFT PER EACH 360° REV. OF INPUT
STOCK NUMBER	
GX-7	90 DEGREES
GX-8	60 DEGREES
GX-9	45 DEGREES
GX-10	30 DEGREES
GX-11	22.5 DEGREES
GX-12	10 DEGREES



# GENEVA MECHANISM

SHAFT	POINTS	MATERIAL
1/4"	4, 5, 6 AND 8	STAINLESS STEEL

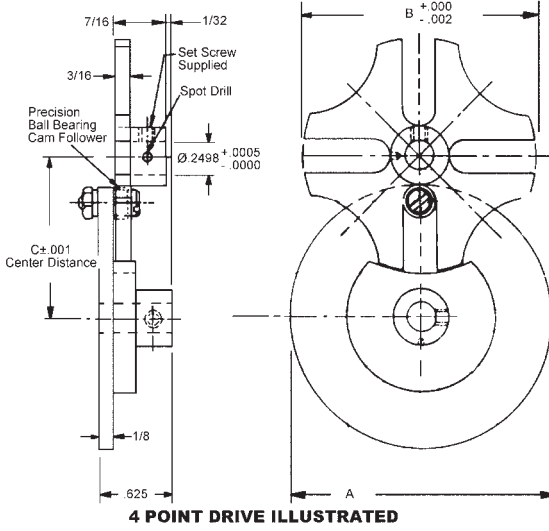

STOCK NO.	NO. ROLLERS ON DRIVER	RELATIVE ROTATION DRIVER TO DRIVEN		POINTS ON DRIVEN	MAX. TORQUE (IN OZ.)	MAX OPER ORQUE (IN OZ.)	A	B	C
GM-1	ONE	360°	90°	4	71	35	2-1/4	1.971	1.3824
GM-1A	TWO	180°							
GM-2	ONE	360°	72°	5	110	55	2-1/4	2.470	1.5187
GM-2A	TWO	180°							
GM-3	ONE	360°	60°	6	175	87	2-1/2	3.468	1.9970
GM-3A	TWO	180°							
GM-4	ONE	360°	45°	8	240	120	2	4.083	2.2056
GM-4A	TWO	180°							

STOCK NO.	DESCRIPTION
JE-1-PH	REPLACEMENT CAM FOLLOWER

5/16" Bore available, call for price, to order, add an "L" to end of Stock Number.



# CAM FOLLOWER

TYPE	MATERIAL	ABEC
BALL BEARING OR BRONZE BEARING	303 STAINLESS STEEL	5

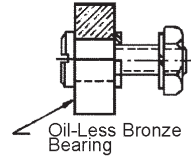
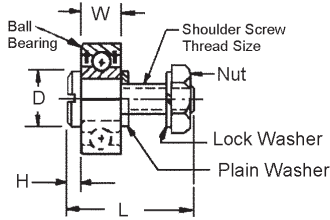
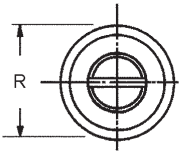

STOCK NO.	R	W	L	D	H	SCREW THREAD	BEARING
JE-1	.2500	.109	.484	3/16	1/8	#4-40	BALL BEARING
JE-2	.3125	.140	.578	7/32	1/8	#4-40	
JE-3	.3750	.156	.593	1/4	1/8	#4-40	
JE-4	.5000	.196	.727	5/16	5/32	#8-32	
JE-5	.6250	.196	.852	3/8	5/32	#10-32	
JE-6	.2500	.140	.484	5/32	3/32	#1-64	
JE-7	.3125	.140	.484	3/16	3/32	#2-56	
JE-1-PH*	.2500	.109	.484	3/16	1/8	#4-40	BRONZE BEARING
JE-B-1	.2500	.093	.483	3/16	1/8	#4-40	
JE-B-3	.3750	.140	.593	1/4	1/8	#4-40	
JE-B-4	.5000	.180	.727	5/16	5/32	#8-32	
JE-B-5	.6250	.180	.852	3/8	5/32	#10-32	



\* Hardened shoulder screw, material is 416 Stainless Steel.

# ROLLER BEARING CAM FOLLOWER

TYPE

HEAVY DUTY

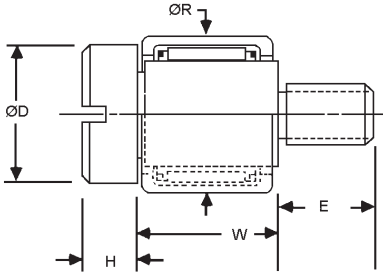

STOCK NO.	$\text{ØR}$	W	$\text{ØD}$	H	E	SCREW THREAD
JE-R-1	.2500	.250	7/32	1/8	5/32	#4-40
JE-R-2	.3438	.250	5/16	5/32	3/16	#8-32
JE-R-3	.3438	.375	5/16	5/32	3/16	#8-32
JE-R-4	.4375	.250	3/8	3/16	1/4	#10-32
JE-R-5	.5000	.312	7/16	7/32	7/16	#1/4-20
JE-R-6	.5625	.312	1/2	1/4	1/2	#5/16-18
JE-R-7	.5625	.625	1/2	1/4	1/2	#5/16-18
JE-R-8	.6875	.750	5/8	5/16	5/8	#3/8-16

## Materials:

**Screw** - 416 Stainless Steel

**Roller Cup** - Case Hardened Steel

**Needle Bearings** - 52100 Hardened Steel

**Bearing Cage** - Low Carbon Steel

See the Bearings Section of this book for Bearings Specifications.

- High Load
- Low Profile
- Low Friction

# ADJUSTABLE CAM ASSEMBLY

BORE SIZES	TYPE	MATERIAL
1/8" TO 1/2"	PIN HUB	303 STAINLESS STEEL

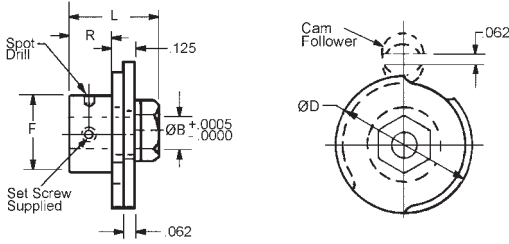

Cam plates are adjustable from 0° to 180°. Order Cam Follower Separately.

STOCK NO.	B	D	F	L	R
JD-1-P	.1248	11/16	5/16	.61	1/4
JD-2-P	.1873		3/8		
JD-3-P	.2498		1/2		
JD-4-P	.1248	1-1/4	5/16	.61	1/4
JD-5-P	.1873		3/8		
JD-6-P	.2498		1/2		
JD-7-P	.3123	2	1-1/4	1.50	1/2
JD-8-P	.3748		1-1/4		
JD-9-P	.4998		1-1/4		

BORE SIZES	TYPE	MATERIAL
1/8" TO 1/2"	CLAMP STYLE	303 STAINLESS STEEL

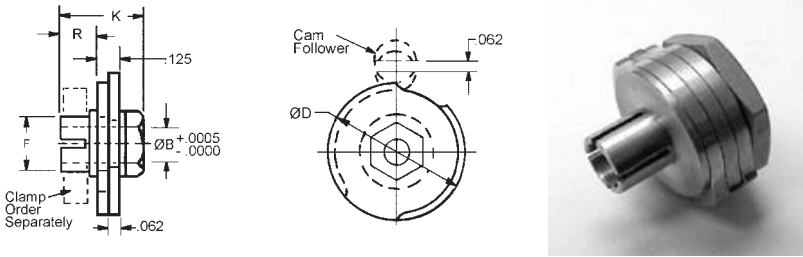

Cam plates are adjustable from 0° to 180°. Order Cam Follower Separately.

STOCK NO.	B	D	F	K	R
CA-1C	.1248	11/16	.188	.61	1/4
CA-2C	.1873		.250		
CA-3C	.2498		.312		
CA-4C	.1248	1-1/4	.188	.61	1/4
CA-5C	.1873		.250		
CA-6C	.2498		.312		
CA-7C	.3123	2	.375	1.25	1/2
CA-8C	.3748		.437		
CA-9C	.4998		.562		

# RATCHETS AND PAWLS

PITCH	STYLE	MATERIAL
16 to 48	RIGHT HAND OPERATION	STAINLESS STEEL

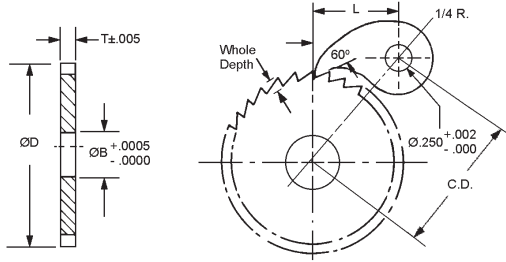

17-4 PH STAINLESS STEEL HARDENED RC 32-38			416 STAINLESS STEEL
STOCK PAWLS			MOUNTING SHOULDER SCREW (Order Separately)
STOCK NO.	T THICKNESS	L LENGTH	
RP-2	.245	3/4	PL-19
RP-375	.370	1-5/16	PL-21

- For Shoulder Screw Dimensions - See Index
- Ratchets Material - 303 Stainless Steel
- Last number in Stock No. indicate the total number of teeth. Special ratchets and pawls made to order, contact us.

RATCHET STOCK NO.	DIAMETRICAL PITCH	OUTSIDE DIA.	BORE	T	C.D. +.06 -.00	WHOLE DEPTH
R16S20-20	16 (.1963 CIRC. PITCH)	1.250	.6871	.375		1.53
R16S20-24		1.500				1.60
R16S20-32		2.000				1.75
R16S20-48		3.000				2.10
R16S20-56		3.500				2.30
R16S20-64		4.000				2.50
R24S6-24	24 (.1309 CIRC. PITCH)	1.000	.3748	.250		1.11
R24S6-30		1.250				1.18
R24S6-36		1.500				1.26
R24S6-48		2.000				1.45
R24S6-72		3.000				1.86
R32S3-24	32 (.0932 CIRC. PITCH)	.750	.3748	.125		1.04
R32S3-32		1.000				1.11
R32S3-40		1.250				1.18
R32S3-48		1.500				1.26
R32S3-64		2.000				1.45
R32S3-96		3.000				1.86
R48S3-36	48 (.0654 CIRC. PITCH)	.750	.3748	.125		1.05
R48S3-48		1.000				1.12
R48S3-60		1.250				1.20
R48S3-72		1.500				1.28
R48S3-96		2.000				1.47
R48S3-144		3.000				1.88

